

PART III

Technical Annex

Some Technical Aspects of Disaster Communications

1 Introduction

In Part 1 of this handbook, the reader was presented with definitions and overall policy considerations regarding disaster communications. Following this general discussion, the reader was invited to consider the more specific guidance required to operate an emergency Telecommunications network as presented in Part 2 designed for operational personnel.

In order to improve the flow of thought in Parts 1 and 2, technical details and formulas are consolidated in Part 3. This permitted the previous two parts to be written in a narrative style. Further, it made the text more readable for planners and policy-makers who require an overview of the problems, solutions and techniques related to emergency telecommunications.

Part 3 is organised into the following sections:

- The selection of the appropriate technology for emergency telecommunications
- Methods of radiocommunication
- Antennas as an essential part of any radio station
- Use of relay stations (repeaters) and trunking systems
- Power sources (including batteries)

In addition, there is a bibliography listing a number of references that will guide the reader to an extensive historical source listing. Also, it will provide information about useful sources of additional information from which it is possible to expand on the subjects raised in briefer form in this Handbook.

At the conclusion, there is an Appendix of a number of useful documents from a number of diverse original sources.

2 The selection of appropriate technologies for Emergency Telecommunications

2.1 Simplicity vs. new technologies

Generally, the simpler time-tested forms of radiocommunication work best in disaster situations. These include single-sideband (SSB) voice and Morse code (CW) telegraphy at HF and FM voice at VHF/UHF.

The equipment has been perfected over time, and its installation, maintenance and operation are widely understood. There are robust versions of equipment designed to meet the rigours of transportation and operation in the field.

Nevertheless, some newer technologies offer features that may facilitate emergency telecommunications. Those include cellular telephones, digital dispatch radios, facsimile, data communications, television and satellites. Each has their advantages and disadvantages, which should be weighed carefully in the planning process.

Emerging technologies such as 3rd generation cellular (IMT-2000), software-defined radio (SDR), broadband and multimedia systems should be evaluated in terms of their ability to function during emergency conditions.

Training of radiocommunication personnel is an important aspect of the selection of appropriate technologies. It is fruitless to plan on an HF Morse telegraphy capability without trained and experienced operators. Use of SSB voice to avoid training Morse operators is not necessarily a solution unless the operators are trained in installation, maintenance and operation of an SSB radio station. It is also inappropriate to introduce new technologies without a continuing supply of personnel adequately trained in system planning, installation, maintenance and operation.

The ideal emergency Telecommunications system is one in routine daily use that has the capability of functioning in disaster and other emergency conditions. Second best is a capability exercised periodically, such as weekly or monthly, under simulated emergency conditions.

2.2 Reliability of the infrastructure

HF communications, whether by SSB voice or Morse telegraphy, normally do not require any infrastructure for relaying or processing. Communication is usually a direct link between the originating station and the addressee. When long distances are involved, such as beyond 2 000 km, or when propagation conditions are poor, base stations or relay stations can be used to facilitate communication but may not necessary be required.

2.3 Transportation and mobility considerations

New technology includes such telecommunication systems as portable satellite earth stations, mobile and portable cellular telephone base stations, and telemedicine video base and remote stations. There are circumstances where it would be desirable to use these new technologies at a disaster area. However, transportation and mobility should be taken into account before using such systems. For example, a satellite earth station that is mounted on pallets requiring special handling equipment for loading and unloading because an aircraft may be available at the point of origin, but not at the point of debarkation.

Further, once the communications system is unloaded at the nearest available airport, ground transportation will be needed to transport it to the disaster area. Trucks and loading equipment are generally in full use at the disaster site and may not be available at an airport.

A third consideration is the condition of roads leading to the disaster area. In many cases, it may not be possible to move the communications equipment to a location where it is most desired because of obstructions.

2.4 Interoperability

The capability to communicate with the local public protection organisations such as police, fire and medical, the local military, international disaster relief organisations and neighbouring countries is an important consideration.

There may be circumstances where it should be possible for any station to be able to communicate with any other station in the disaster area. Such a feature can cut across the formal structure and get communications directly to the intended party without experiencing delays and possible misinterpretation by intermediaries. Unfortunately, there are other circumstances where separate channels are needed for different groups of stations and it would be difficult if not impractical for everyone to be on one channel.

2.5 Comparison of satellite systems for emergency telecommunications

2.5.1 Low Earth orbit satellites

Low Earth orbit (LEO) satellites may be used to relay radio signals far beyond line-of-sight. Depending on altitude, a single LEO satellite could be used to relay signals over paths up to about 5 000 km when the two earth stations are both visible to the satellite. Such visibility lasts only for a few minutes at such extreme distances. Stations closer together can have mutual visibility to the satellite for longer periods, perhaps up to 20 minutes on a favourable pass. Owing to their orbits, single LEO satellite have the disadvantage that they can provide real time communication only for a few times a day.

LEO constellations can be used for continuous real time relay. This requires a sufficient number of satellites to assure that at least one is visible to a point on Earth at all times. Also, there must be a means of networking the satellites, either through inter-satellite (satellite-to-satellite) links or via earth stations located throughout the world.

2.5.2.1 INMARSAT vs. VSAT and USAT

Common telephone and data services are available from land-based satellite terminal systems using the portable International Maritime Satellite (INMARSAT) or the semi-fixed Very Small Aperture Terminal (VSAT) satellite network. These services include voice, facsimile and electronic mail communications. Any device that works with a common telephone device may be used with these satellite systems. In addition to the above-mentioned services, some satellite terminals offer transfer of digital photographs or live video conferencing.

The choice of whether to use INMARSAT or VSAT is dependent upon the particular Telecommunications requirements for the system. Many variable factors will influence the choice of one over the other: cost, mobility, and the need for high volume use. Also, the ability of the system to support various modes of communication, such as: standard voice, computer data (networked or stand-alone e-mail connections), facsimile, text-only messages and videoconferencing.

Inmarsat provides a global mobile satellite communications capability with several advantages to support disaster preparedness and relief operations. Inmarsat terminals are self-sufficient and can be operational within 5-10 minutes of arriving at the disaster scene. They are independent from local Telecommunications infrastructures, and can be operated with batteries or generator power suppliers. Inmarsat systems can be configured to provide communications between two independent relief teams working in the same locality or to provide direct links to relief agencies and material suppliers worldwide. One important detail is that Inmarsat equipment is simple to operate, and can be set up and operated by untrained personnel using instructions provided with the units. The equipment is compact and lightweight. Some models can be hand carried.

Inmarsat's primary satellite constellation consists of four Inmarsat I-3 satellites in geostationary orbit. A fifth spacecraft that can be brought in to provide additional capacity currently backs these up. Between them, the main "global" beams of the satellites provide overlapping coverage of the whole surface of the Earth apart from the poles. So, with Inmarsat coverage, it has become possible to extend the reach of terrestrial wired and cellular networks to almost anywhere on Earth.

Figure 2 – Mobile Satellite Communications

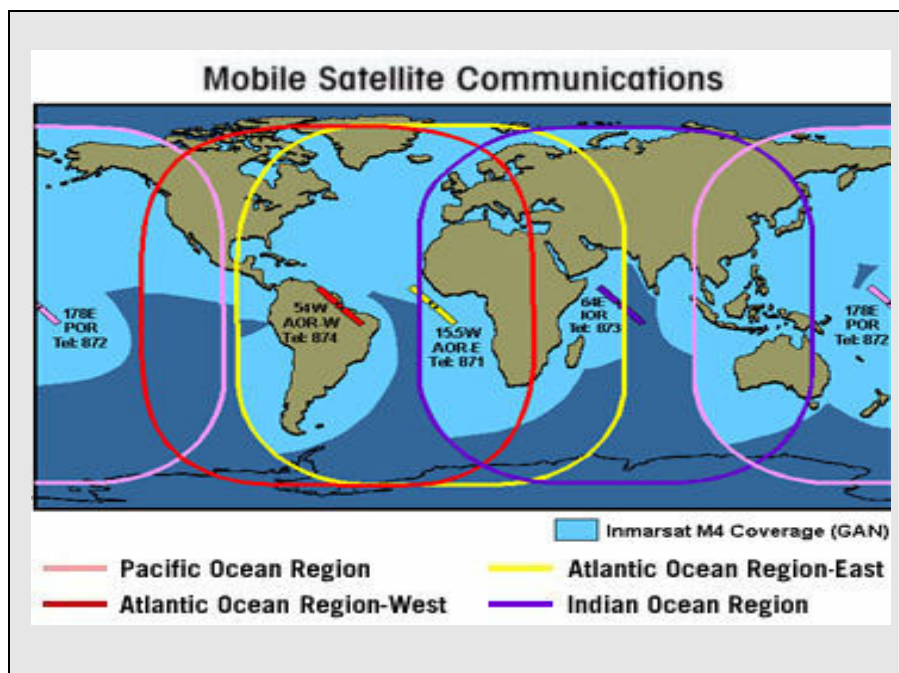

A geostationary satellite follows a circular orbit in the plane of the Equator at a height of 35,600 km, so that it appears to hover over a chosen point on the Earth's surface. Three such satellites are enough to cover most of the globe, and mobile users rarely have to switch from one satellite to another. Other mobile satellite systems use larger numbers of satellites in lower, non-geostationary orbits. From the user's point of view, they move across the sky at a comparatively high speed, often requiring a switch from one satellite to another in mid-communication and risking the possibility of an interrupted call.

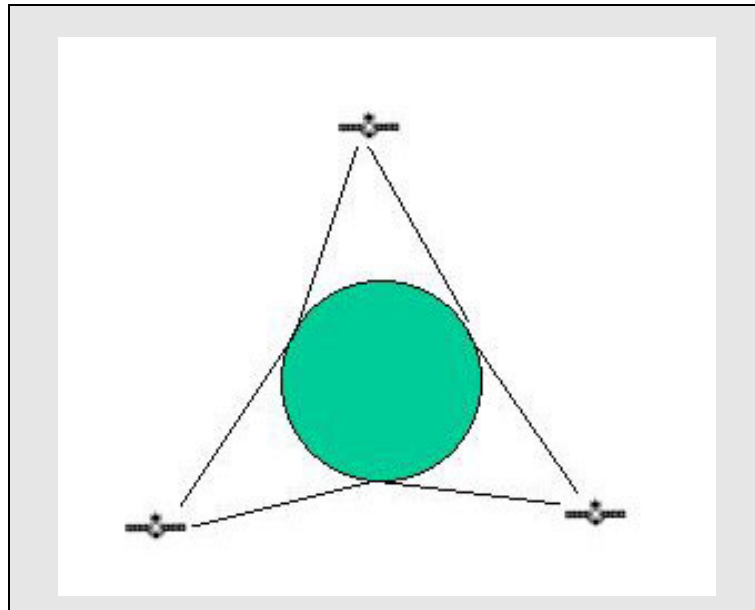
Figure 3 – Three satellites in geostationary orbit can cover the entire Earth

The satellites are controlled from the Satellite Control Centre (SCC) at Inmarsat HQ in London. The control teams there are responsible for keeping the satellites in position above the Equator, and for ensuring that the onboard systems are fully functional at all times.

Data on the status of the nine Inmarsat satellites is supplied to the SCC by four tracking, telemetry and control (TT&C) stations located at Fucino, Italy; Beijing in China; Lake Cowichan, western Canada; and Pennant Point, eastern Canada. There is also a back-up station at Eik in Norway.

A call from an Inmarsat mobile terminal goes directly to the satellite overhead, which routes it back down to a gateway on the ground called a land earth station (LES). From there the call is passed into the public phone network.

The Inmarsat I-3 satellites are supported by four previous-generation Inmarsat-2s, also in geostationary orbit.

A key advantage of the Inmarsat I-3s over their predecessors is their ability to generate a number of spotbeams as well as single large global beams. Spotbeams concentrate extra power in areas of high demand, as well as making it possible to supply standard services to smaller, simpler terminals.

Inmarsat I-2 – Purpose-built quartet

Launched in the early 1990s, the four second-generation satellites were built to Inmarsat specification by an international group headed by British Aerospace (now BAE Systems).

The three-axis-stabilized Inmarsat I-2s were designed for a 10-year life. Inmarsat-2 F1 was launched in 1990 and is now located over the Pacific, providing lease capacity. F2, launched in 1991, is over the western Atlantic, providing leased capacity and backing up Inmarsat I-3 F4. Also orbited in 1991, F3 is stationed over the Pacific Ocean, providing lease capacity and backing up Inmarsat I-3 F3. The fourth Inmarsat-2 was launched in 1992 and is used to provide leased capacity over the Indian Ocean and backing up Inmarsat I-3 F1 and Inmarsat I-3 F3.

Inmarsat-3: A story of spotbeams

Launched in 1996-8, the Inmarsat I-3s were built by Lockheed Martin Astro Space (now Lockheed Martin Missiles & Space) of the USA, responsible for the basic spacecraft, and the European Matra Marconi Space (now Astrium), which developed the communications payload.

The Inmarsat I-3 communications payload can generate a global beam and a maximum of seven spotbeams. The spotbeams are directed as required to make extra communications capacity available in areas where demand from users is high.

Inmarsat I-3 F1 was launched in 1996 to cover the Indian Ocean Region. Over the next two years F2 entered service over Atlantic Ocean Region-East, followed by F3 (Pacific Ocean Region), F4 (Atlantic Ocean Region-West) and F5 (limited services on a single spot beam, back-up and leased capacity).

Inmarsat I-4: Gateway to Broadband

Responding to the growing demand from corporate mobile satellite users for high-speed Internet access and multimedia connectivity, Inmarsat has been building its fourth generation of satellites.

The company awarded European spacecraft manufacturer Astrium the contract to build the three Inmarsat I-4 satellites. Astrium is the European company that includes the former Matra Marconi Space, which built the Inmarsat I-2 satellites and the payload for the Inmarsat I-3s.

The job of the satellites will be to support the new Broadband Global Area Network (BGAN), currently scheduled to enter service in 2005 to deliver Internet and intranet content and solutions, video-on-demand, videoconferencing, fax, e-mail, phone and LAN access at speeds up to 432 kbit/s almost anywhere in the world. BGAN will also be compatible with third-generation (3G) cellular systems.

The satellites, the world's largest commercial communications satellites, will be 100 times more powerful than the present generation and BGAN will provide at least 10 times as much communications capacity as today's Inmarsat network.

The spacecraft will be built largely in the United Kingdom. The bus will be assembled at Astrium's factory in Stevenage and the payload in Portsmouth. The two sections will then be united in Toulouse, France, together with the US-built antenna and German-built solar arrays.

Inmarsat maritime communications and safety services contribute significantly to the safe and efficient management of ocean-going vessels whether merchant, fishing or leisure and luxury yachts.

Fleet Services

Fleet F77, F55 and F33 provide high-quality mobile voice and flexible data communications services, e-mail and secure Internet access for the maritime industry.

Fleet F77

Inmarsat Fleet F77 is a successor to the Inmarsat B service for deep-sea vessels. In addition to voice and fax, Fleet F77 provides both Mobile ISDN and the Mobile Packet Data Service (MPDS).

The 128 kbit/s ISDN channel enables large volumes of data to be transferred cost-effectively, and remote diagnostics to be carried out.

MPDS brings always-on connectivity to the bridge, with fully integrated Internet Protocol (IP) functionality. Operators are charged by the volume transferred, not for the time spent online, making it a cost-effective service for a range of applications. Officers and crew can access the Internet and browse the web, providing them with education, entertainment and information services.

Inmarsat Fleet F77 also meets the latest distress and safety requirements as specified by the International Maritime Organization (IMO) in resolution A.888 for voice pre-emption and prioritization within the Global Maritime Distress and Safety System (GMDSS).

Applications: data transfer; Internet; LAN and private network access; e-mail; fax; instant messaging; SMS; voice; crew calling; encryption; video-conferencing; store-and-forward video; remote monitoring; chart and weather updates; telemedicine; GMDSS.

Fleet F55

Fleet F55 uses a medium-sized antenna for smaller vessels, and offers the 64 kbit/s Mobile ISDN and MPDS capabilities in the spotbeam areas, plus global voice. Smaller vessels, like trawlers and yachts, are not required to meet IMO regulations, so Fleet F55 and F33 do not include a GMDSS component.

Applications: data transfer; Internet; LAN and private network access; e-mail; fax; instant messaging; SMS; voice; crew calling; encryption; videoconferencing; store-and-forward video; remote monitoring; chart and weather updates; telemedicine.

Fleet F33

F33 offers global telephone, as well as the Mobile Packet Data Service (MPDS) and enhanced 9.6 kbit/s data and fax services within the Inmarsat spotbeams, providing a wide range of applications to the small vessel market.

Applications: data transfer; Internet; LAN and private network access; e-mail; fax; instant messaging; SMS; voice; crew calling; encryption; store-and-forward video; remote monitoring; chart and weather updates; telemedicine

Inmarsat mini-M

Inmarsat mini-M provides voice and 2.4 kbit/s data (or 9.6 kbit/s using compression) within the Inmarsat spotbeams. It makes the ideal Crew Calling solution when a payphone or crew extension is connected.

Applications: data transfer; e-mail; fax; voice; crew calling; encryption; telemedicine.

Inmarsat C

A two-way, packet data service via lightweight, low-cost terminals small enough to be fitted to any vessel. Approved for use under the Global Maritime Distress and Safety System (GMDSS), it provides seven of the key GMDSS functions. Inmarsat C is ideal for distributing and collecting information from fleets of commercial vessels. It also meets the requirements for Ship Security Alert Systems (SSAS).

Applications: data transfer; e-mail; SMS, crew calling; telex; remote monitoring; tracking; chart and weather updates; maritime safety information (MSI); maritime security; GMDSS; and SafetyNET and FleetNET services.

Inmarsat mini-C

Inmarsat mini-C offers the same primary functions as Inmarsat C through a lower-power, more cost-effective terminal. It is also GMDSS compatible and meets the requirements for Ship Security Alert Systems (SSAS).

Applications: data transfer; e-mail; SMS, remote monitoring; and tracking; maritime security.

Handbook on Emergency Telecommunications

Inmarsat D+

A two-way data communications service from equipment the size of a personal CD player. With an integral GPS, Inmarsat D+ can be used for remote surveillance, asset tracking and short information broadcasts. It meets the requirements for Ship Security Alert Systems (SSAS).

Applications: data transfer; remote monitoring; tracking.

Inmarsat E/E+

The Inmarsat E emergency position indicating radio beacon (EPIRB) is a key element of GMDSS. Distress alerts are transmitted from the EPIRB when the unit floats free from a sinking vessel, or when activated manually, and are forwarded automatically to a Maritime Rescue Coordination Centre. Inmarsat E+ adds a key return channel to the EPIRB, which sends a confirmation to the seafarer that their alert has been received.

Applications: GMDSS.

Inmarsat A

The Inmarsat A system provides two-way direct-dial phone connection, including high-quality voice, fax, telex, e-mail and data communications to and from anywhere in the world with the exception of the poles. It also provides distress communication capabilities. It is based on analogue technology and supports data rates of between 9.6 kbit/s up to 64 kbit/s depending on different elements of the end-to-end connection.

Applications: voice; fax; telex; e-mail; data; GMDSS.

Inmarsat B

This remains a core service for the maritime industry. Voice, data at speeds from 9.6 kbit/s to 64 kbit/s, telex and fax are supported, in addition to voice, distress and safety.

Applications: data transfer; Internet; LAN and private network access; e-mail; fax; SMS; voice; crew calling; encryption; video-conferencing; store-and-forward video; remote monitoring; chart and weather updates; telemedicine; GMDSS.

Inmarsat M

Provides global voice and 2.4 kbit/s data on a medium-sized antenna.

Applications: data transfer; fax; voice.

Airtime services for Inmarsat satellites are available worldwide through a network of about 100 service providers. Some service providers also operate Inmarsat land earth stations. There are about 40 such stations in 31 countries. These stations receive and transmit communications through the Inmarsat satellites and provide the connection between the satellite system and the fixed communications networks.

2.5.2.2 VSAT

Very Small Aperture Terminal (VSAT) is a satellite communications technology using small earth antenna, usually 0.9 and 1.8 meters in diameter, for reliable voice, data, audio, video, multimedia, and wide-band service transmission. VSAT services constitute a network composed of a series of remote points connected to a main control centre, which in turn is connected through space with a data centre or central processor: the central station and a large number of geographically disbursed sites. One of the many applications of this technology is Internet via satellite.

VSAT communication networks are comprised of a space and a land segment. The space segment is comprised of a geostationary satellite, which amplifies and changes frequencies. The land component consists of a central station or *hub* and remote VSAT stations. VSAT networks can be configured in star-like or mesh shapes, based on the normal flow of communications through the hub or can be sent directly between the VSAT stations (with no need for double hopping).

Changes in technology have led to a reduction in antenna size and have decreased the cost and size of electronics, increased bandwidths and permitted better management capabilities.

When the communication requirement is to provide a long distance link between two or more nodes of a fixed network, a user may select VSAT for such full time, guaranteed bandwidth. For example, some Internet service providers in South America and Africa connect their router to the main Internet by a VSAT full time high-speed link.

VSAT can provide a single communications platform capable of providing service to an entire country or region. For semi-permanent or permanent applications with a large volume of traffic, VSAT may prove to be the best option for Telecommunications service.

For VSAT terminals, set-up time varies from 30 minutes to 3 hours, depending on system complexity.

2.5.2.3 USAT Networks

The diffusion of VSAT networks in fixed-satellite service (FSS) with small-antenna earth stations at distant locations – such as the terraces of office buildings, hotels, shopping centres and other useful locations – has stimulated the development of antennas that are even smaller than VSATs, generally with an effective aperture of less than 1 m. In general, they are known as ultra small aperture terminals (USATs). Antenna discrimination naturally deteriorates as its size decreases.

Satellite service provides wide-band and direct access to the backbone of the Internet for reception and/or reception-transmission of Internet information. Point-to-multipoint connections using high-speed frame relay technology are used. Standard Single Channel Per Carrier (SCPC) satellite connections can also be used. Or both systems can be used for the purposes of redundancy.

3 Methods of radiocommunication

3.1 Frequencies

Radio frequencies should be selected according to propagation requirements, allocation to the service for which they are used and in accordance with licensing regulations of the country in which the station is operating.

Example 1: An amateur station licensed to operate in the country may use a frequency of 7 050 kHz to communicate via sky wave with a station 300 km away, as this frequency is within the 7 MHz amateur allocation.

Example 2: A land mobile station licensed to operate in a country and assigned an operating frequency of 151.25 MHz may use this frequency to communicate up to about 60 km with other authorised stations.

3.1.1 International frequency allocations

The radio frequency spectrum is divided into bands of frequencies by means of international treaty conferences of the International Telecommunication Union (ITU). These bands are allocated to specific radio services and are listed in Article S5 of the international Radio Regulations. Some bands are allocated to the same service(s) worldwide, while others are allocated to different services on a regional basis. The three Regions are shown in the following map.

Figure 4 – ITU radio regions

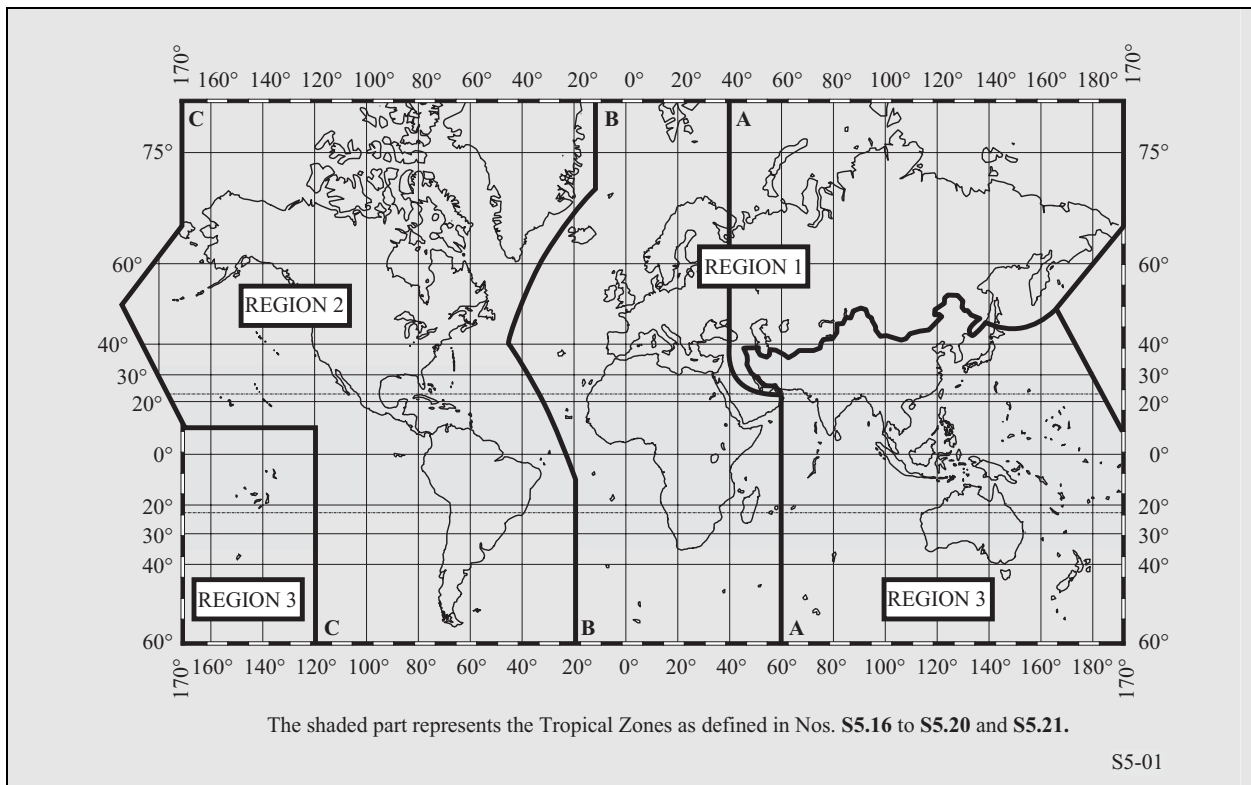

A simplified table of frequencies allocated to the amateur, fixed and mobile services is shown in Table 1.

Table 1 – Allocation to amateur, fixed and mobile services (simplified, footnotes omitted)

| Region 1 | Region 2 | Region 3 |
|--|---|--|
| 1 810-1 850 AMATEUR | 1 800-1 850 AMATEUR | 1 800-2 000 AMATEUR FIXED |
| 1 850-2 000 FIXED MOBILE except aeronautical mobile | 1 850-2 000 AMATEUR FIXED MOBILE except aeronautical mobile | MOBILE except aeronautical mobile |
| 2 000-2 045 FIXED MOBILE except aeronautical mobile (R) | 2 000-2 065 FIXED MOBILE | |
| 2 045-2 160 FIXED MOBILE | | |
| | 2 107-2 170 FIXED MOBILE | |
| 2 194-2 300 FIXED MOBILE except aeronautical mobile (R) | 2 194-2 300 FIXED MOBILE | |
| 2 502-2 625 FIXED MOBILE except aeronautical mobile (R) | 2 505-2 850 FIXED MOBILE | |
| 2 650-2 850 FIXED MOBILE except aeronautical mobile (R) | | |
| 3 155-3 400 | FIXED MOBILE except aeronautical mobile (R) | |
| 3 500-3 800 AMATEUR FIXED MOBILE except aeronautical mobile | 3 500-3 750 AMATEUR | 3 500-3 900 AMATEUR FIXED MOBILE |
| 3 800-3 900 FIXED LAND MOBILE | 3 750-4 000 AMATEUR FIXED MOBILE except aeronautical mobile (R) | |
| 3 950-4 000 FIXED | | |
| 4 000-4 063 | FIXED | |
| 4 438-4 650 FIXED MOBILE except aeronautical mobile (R) | 4 438-4 650 FIXED MOBILE except aeronautical mobile | |
| 4 750-4 850 FIXED LAND MOBILE | 4 750-4 850 FIXED MOBILE except aeronautical mobile (R) | 4 750-4 850 FIXED Land mobile |
| 4 850-4 995 | FIXED LAND MOBILE | |
| 5 005-5 060 | FIXED | |
| 5 060-5 450 | FIXED Mobile except aeronautical mobile | |
| 5 450-5 480 FIXED LAND MOBILE | | 5 450-5 480 FIXED LAND MOBILE |
| 5 730-5 900 FIXED MOBILE except aeronautical mobile (R) | 5 730-5 900 FIXED MOBILE except aeronautical mobile (R) | 5 730-5 900 FIXED Mobile except aeronautical mobile (R) |
| 6 765-7 000 | FIXED Land mobile | |
| 7 000-7 100 | AMATEUR AMATEUR-SATELLITE | |
| | 7 100-7 300 AMATEUR | |
| 7 350-8 100 | FIXED Land mobile | |
| 8 100-8 195 | FIXED | |
| 9 040-9 400 | FIXED | |
| 9 900-9 995 | FIXED | |
| 10 100-10 150 | FIXED Amateur | |
| 10 150-11 175 | FIXED Mobile except aeronautical mobile (R) | |
| 11 400-11 600 | FIXED | |

Handbook on Emergency Telecommunications

| Region 1 | Region 2 | Region 3 |
|--|---|---------------------------------|
| 12 100-12 230 | FIXED | |
| 13 360-13 410 | FIXED | |
| 13 410-13 570 | FIXED Mobile except aeronautical mobile (R) | |
| 13 870-14 000 | FIXED Mobile except aeronautical mobile (R) | |
| 14 000-14 250 | AMATEUR AMATEUR-SATELLITE | |
| 14 250-14 350 | AMATEUR | |
| 14 350-14 990 | FIXED Mobile except aeronautical mobile (R) | |
| 15 800-16 360 | FIXED | |
| 17 410-17 480 | FIXED | |
| 18 030-18 068 | FIXED | |
| 18 068-18 168 | AMATEUR AMATEUR-SATELLITE | |
| 18 168-18 780 | FIXED Mobile except aeronautical mobile | |
| 19 020-19 680 | FIXED | |
| 19 800-19 990 | FIXED | |
| 20 010-21 000 | FIXED Mobile | |
| 21 000-21 450 | AMATEUR AMATEUR-SATELLITE | |
| 21 850-21 924 | FIXED | |
| 22 855-23 000 | FIXED | |
| 23 000-23 200 | FIXED Mobile except aeronautical mobile (R) | |
| 23 200-23 350 | FIXED | |
| 23 350-24 000 | FIXED MOBILE except aeronautical mobile | |
| 24 000-24 890 | FIXED LAND MOBILE | |
| 24 890-24 990 | AMATEUR AMATEUR-SATELLITE | |
| 25 010-25 070 | FIXED MOBILE except aeronautical mobile | |
| 25 210-25 550 | FIXED MOBILE except aeronautical mobile | |
| 26 175-27 500 | FIXED MOBILE except aeronautical mobile | |
| 27.5-28 | FIXED MOBILE | |
| 28-29.7 | AMATEUR AMATEUR-SATELLITE | |
| 29.7-47 | FIXED MOBILE | |
| | 47-50 FIXED MOBILE | 47-50 FIXED MOBILE |
| | 50-54 AMATEUR | |
| | 54-68 Fixed Mobile | 54-68 FIXED MOBILE |
| 68-74.8 FIXED MOBILE except aeronautical mobile | 68-72 Fixed Mobile | 68-74.8 FIXED MOBILE |
| | 72-73 FIXED MOBILE | |
| | 74.6-74.8 FIXED MOBILE | |
| 75.2-87.5 FIXED MOBILE except aeronautical mobile | 75.2-75.4 FIXED MOBILE | 75.4-87 FIXED MOBILE |
| | 75.4-76 FIXED MOBILE | |
| | 76-88 Fixed Mobile | |
| | | 87-100 FIXED MOBILE |
| 137-138 | Fixed Mobile except aeronautical mobile (R) | |
| | 138-144 FIXED MOBILE | 138-144 FIXED MOBILE |
| 144-146 | AMATEUR AMATEUR-SATELLITE | |
| 146-148 FIXED MOBILE except aeronautical mobile (R) | 146-148 AMATEUR | 146-148 AMATEUR FIXED MOBILE |
| 148-149.9 FIXED MOBILE except aeronautical mobile (R) | 148-149.9 FIXED MOBILE | |

| Region 1 | Region 2 | Region 3 |
|---|---|----------------------|
| 150.05-174 FIXED MOBILE except aeronautical mobile | 150.05-174 FIXED MOBILE | |
| | 174-216 Fixed Mobile | 174-223 FIXED MOBILE |
| | 216-220 FIXED | |
| | 220-225 AMATEUR | |
| 223-230 Fixed Mobile | FIXED MOBILE | 223-230 FIXED MOBILE |
| 401-406 | Fixed Mobile except aeronautical mobile | |
| 406.1-430 | FIXED MOBILE except aeronautical mobile | |
| 430-440 AMATEUR | 430-440 Amateur | |
| 440-450 | FIXED MOBILE except aeronautical mobile | |
| 450-470 | FIXED MOBILE | |

3.1.2 National frequency allocations

The frequency allocation tables of most countries closely follow the international table of allocations. There are exceptions and it is necessary to be aware of, and adhere to, national radio regulations concerning frequencies and their use.

3.1.3 Frequency assignments

Assignment of specific radio frequencies to radio stations is made by national administrations. This is the case for the fixed and mobile services. Amateur stations do not normally have frequency assignments and are free to select a specific operating frequency dynamically within an allocated band.

In some cases, administrations may assign frequencies to services not allocated to those services in the international table of allocations on a non-interference basis. This is provided for in the Radio Regulations, as follows:

- **S4.4** Administrations of the Member States shall not assign to a station any frequency in derogation of either the Table of Frequency Allocations in this Chapter or the other provisions of these Regulations, except on the express condition that such a station, when using such a frequency assignment, shall not cause harmful interference to, and shall not claim protection from harmful interference caused by, a station operating in accordance with the provisions of the Constitution, the Convention and these Regulations.

In times of emergency, administrations may use the following provision of the Radio Regulations:

- **S4.9** No provision of these Regulations prevents the use by a station in distress, or by a station providing assistance to it, of any means of radiocommunication at its disposal to attract attention, make known the condition and location of the station in distress, and obtain or provide assistance.

Stations in the fixed and mobile services having emergency communications missions should have a family of frequencies from which to select according to propagation for specific paths.

3.2 Propagation

Radio signals are electromagnetic waves that travel through the Earth's atmosphere and into space. These waves propagate by means of different mechanisms, such as surface wave, direct or space wave (line-of-sight), diffraction (knife-edge propagation), ionospheric refraction (sky wave), tropospheric refraction and tropospheric ducting. Ionospheric propagation varies according to time of day, season of the year, solar

activity (sunspot number), path distance, and location of the transmitters and receivers. Tropospheric propagation is somewhat related to weather conditions.

Recommendation ITU-R P.1144, the guide to the propagation methods of Radiocommunication Study Group 3, may be used to determine which propagation methods should be used for different applications. Computer programmes are also available and are available from ITU-R.

3.2.1 Ground wave

Ground waves are those confined to the Earth's lower atmosphere. Distances are dependent on transmitter power, antenna efficiency, ground conductivity and atmospheric noise levels. Ground-wave propagation curves for frequencies between 10 kHz and 30 MHz are given in Recommendation ITU-R P.368. For practical emergency communications, ground waves are useful only at lower high frequencies (near 3 MHz) and for relatively short distances of a few kilometres.

3.2.2 Sky wave propagation

Sky waves use the Earth's ionosphere to refract the signal. The ionosphere is formed by several layers, which are identified by letters of the alphabet. The *D layer* lies between about 60 and 92 km above the Earth. The *E layer* is about 100 to 115 km above the Earth. The D layer is used for medium frequency sky wave propagation. The D and E layers absorb signals at frequencies in the lower part of the HF band around 3 MHz. The *F layer* (about 160 to 500 km) may split into two layers, *F₁* and *F₂* and can support frequencies over the entire HF band at long distances. Frequencies and distances vary according to the specific path, time of day, season and solar activity. Sky wave propagation for the frequency range 2-30 MHz may be predicted using Recommendation ITU-R P.533.

Figure 5 – Illustration of how HF radio signals travel through the ionosphere. Frequencies above the maximum usable frequency (MUF) penetrate the ionosphere and go into space. Frequencies below the MUF are refracted back to the Earth. Ground waves, skip zones and multiple hop paths are shown

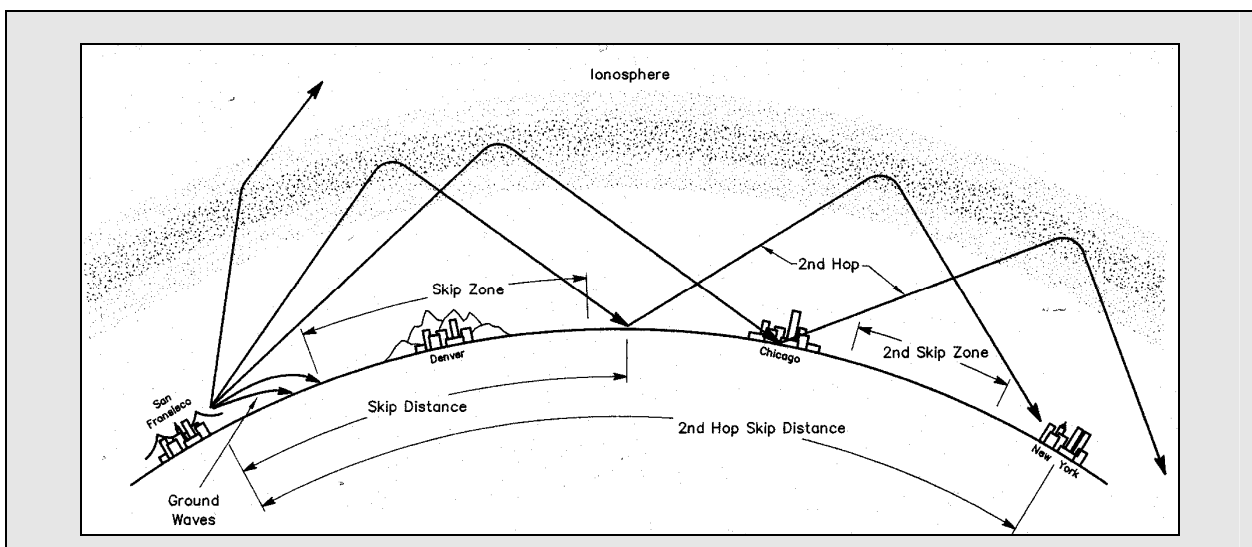

3.2.2.1 Near-vertical-incidence sky wave

Near-vertical-incidence sky wave (NVIS) is a term describing high angle ionospheric paths covering short distances. It is particularly useful for distances just beyond those practical for VHF or UHF. To be successful, it is necessary to select frequencies below the critical frequency, which means that frequencies will be in the 2-6 MHz range, the higher end during the daytime and the lower part of the range at night. Antenna take-off angle is essentially straight overhead so a practical antenna is horizontally polarised and just a few meters above ground.

3.2.3 VHF/UHF propagation

Radio signals travel somewhat beyond the optical line-of-sight, as though the Earth were 4/3 its size. The radio horizon for VHF/UHF signals can be approximated by:

$$D = 4.124 h^{-2}$$

where:

D: distance in kilometers

h^{-2} : square root of the antenna height above ground in meters

Free-space propagation loss may be calculated using Recommendation ITU-R P.525.

Figure 6 – The ionosphere consists of several regions of ionised particles at different heights above Earth. At night, the D and E regions disappear. The F₁ and F₂ regions combine to form a single F region at night

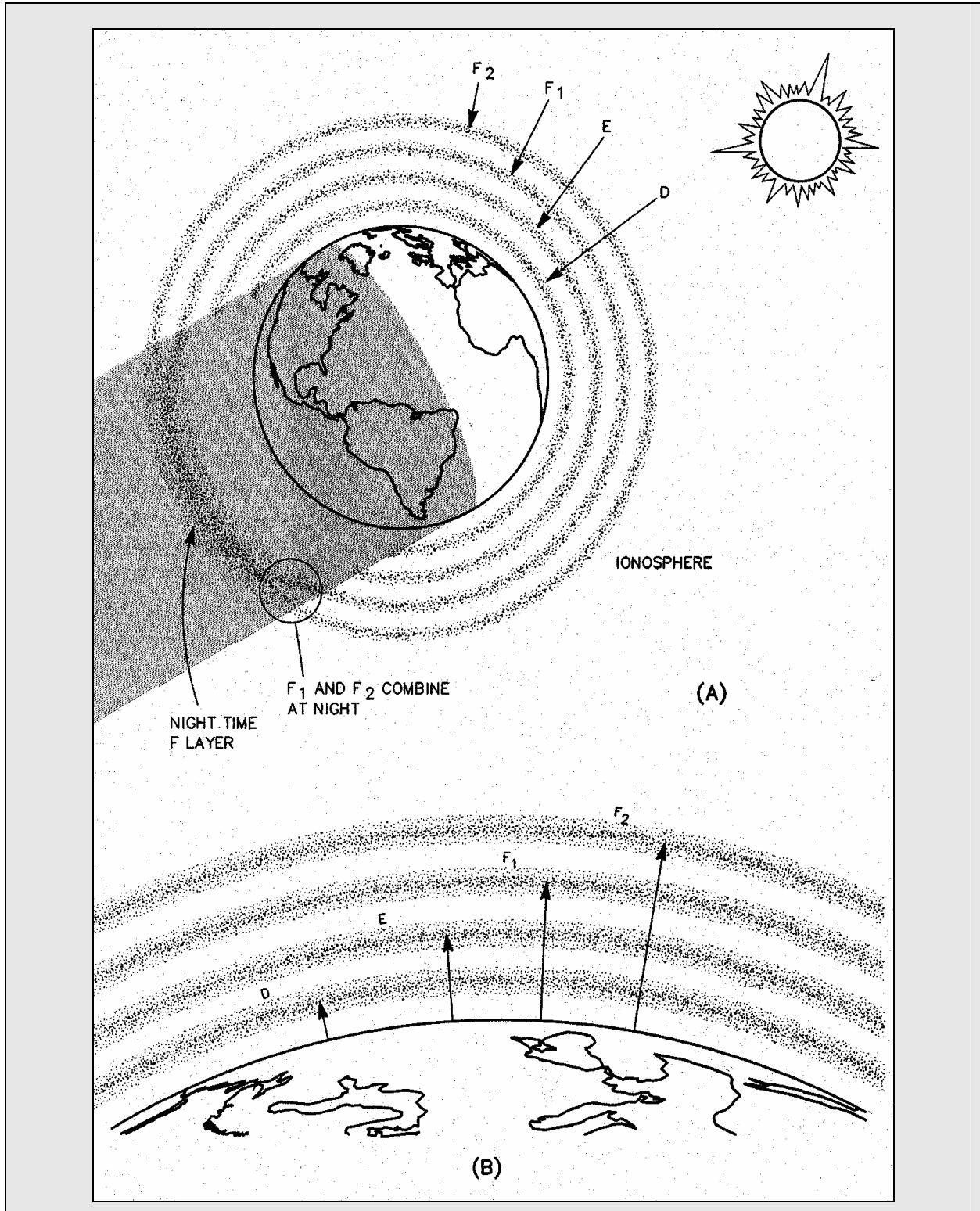
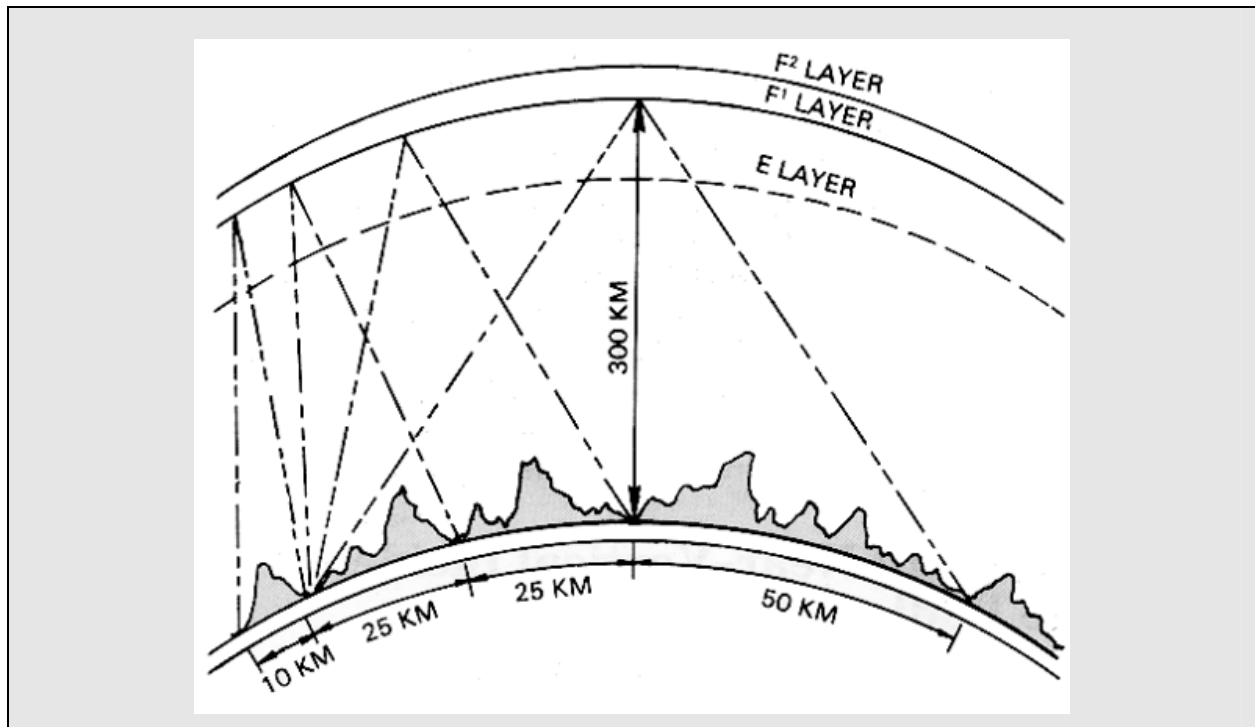

Figure 7 – Near-vertical incidence sky wave paths



3.2.3.1 Point-to-area links

If there is a transmitter serving several randomly distributed receivers (for example in the mobile service), the field is calculated at a point located at some appropriate distance from the transmitter by the expression:

$$e = \frac{\sqrt{30p}}{d}$$

where:

e : r.m.s. field strength (V/m) (see Note 1),

p : equivalent isotropically radiated power (e.i.r.p.) of the transmitter in the direction of the point in question (W),

d : distance from the transmitter to the point in question (m).

Land mobile point-to-area propagation for the VHF (10-600 km) and UHF (1-100 km) may be predicted using Recommendation ITU-R P.529.

3.2.3.2 Point-to-point links

With a point-to-point link it is preferable to calculate the free-space attenuation between isotropic antennas, also known as the free-space basic transmission loss (symbols: L_{bf} or A_0), as follows:

$$L_{bf} = 20 \log \left(\frac{4\pi d}{\lambda} \right) \text{ dB}$$

where:

L_{bf} : free-space basic transmission loss (dB),

d : distance,

λ : wavelength, and

d and λ are expressed in the same unit.

The above equation can also be written using the frequency instead of the wavelength.

$$L_{bf} = 32.4 + 20 \log f + 20 \log d \quad \text{dB}$$

where:

f : frequency (MHz),

d : distance (km).

Point-to-area propagation for 150 MHz – 40 GHz for distances up to 200 km may be predicted using Recommendation ITU-R P.530

3.2.3.3 Conversion formulas

On the basis of free-space propagation, the following conversion formulas may be used.

Field strength for a given isotropically transmitted power:

$$E = P_t - 20 \log d + 74.8$$

Isotropically received power for a given field strength:

$$P_r = E - 20 \log f - 167.2$$

Free-space basic transmission loss for a given isotropically transmitted power and field strength:

$$L_{bf} = P_t - E + 20 \log f + 167.2$$

Power flux-density for a given field strength:

$$S = E - 145.8$$

where:

P_t : isotropically transmitted power (dB(W))

r : isotropically received power (dB(W))

E : electric field strength (dB(μ V/m))

f : frequency (GHz)

d : radio path length (km)

L_{bf} : free-space basic transmission loss (dB)

S : power flux-density (dB(W/m²)).

For further information on point-to-point line-of-sight propagation refer to Recommendation ITU-R P. 530.

4 Antennas as an essential part of any radio station

4.1 Choosing an antenna

Communicators quickly learn two antenna truths:

- Any antenna is better than no antenna.
- Time, effort and money invested in the antenna system generally will provide more improvement to communications than an equal investment to any other part of the station.

The antenna converts electrical energy to radio waves and radio waves to electrical energy, which makes two-way radio communication possible with just one antenna.

Success in communicating depends heavily on an antenna. A good antenna can make a fair receiver perform well. It can also make a few watts sound like much more. Since the same antenna is used to transmit and receive, any improvements to the antenna make the signal stronger at the desired reception points. Some antennas work better than others. It is useful to experiment with different antenna types.

4.2 Antenna system considerations

4.2.1 Safety

Safety should be the first consideration in installing an antenna system.

An antenna or transmission line should never be installed on top of electrical power lines. A vertical antenna should never be located where it could fall against the electrical power lines. Electrocutation could result if power lines ever come into contact with the antenna.

Antennas should be high enough above the ground to ensure that no one can touch them. When the transmitter is active, the high voltages present at the ends of an antenna could kill or at least cause a serious RF burn.

A lightning arrester should be placed on the transmission line at the entrance point to the building housing the transmitting and receiving equipment. For safety, an Earth ground connection is necessary and the wire used for that purpose should be of conductor size equivalent to at least 2.75 mm diameter wire. The heavy aluminium wire used for TV-antenna Earth grounds is satisfactory. Copper braid 20 mm wide is also suitable. Ground connection may be made to a metal water pipe system, the grounded metal frame of a building, or to one or more 15 mm diameter ground rods driven to a depth of at least 2.5 meters.

Antenna work sometimes requires that someone climb up on a tower, into a tree, or onto the roof. It is not safe to work alone. Each move should be planned beforehand. The person on a ladder, tower, tree or rooftop should always wear a safety belt and keep it securely anchored. Before each use, the safety belt should be inspected carefully for damage such as cuts or worn areas. The belt will make it much easier to work on the antenna and will also prevent an accidental fall. A hard hat and safety glasses are also important safety equipment.

Tools should not be carried by hand when climbing. They should be placed on a tool belt. A long rope leading back to the ground should be secured to the belt and can be used to pull up other needed objects. It is helpful (and safe) to tie strings or lightweight ropes to all tools. This will save time in retrieving dropped tools and reduce the chances of injuring a helper on the ground.

Helpers on the ground should never stand directly under the work being done. All ground helpers should wear hard hats and safety glasses for protection. Even a small tool can cause an injury if it falls from 15 or 20 meters. A helper should always observe the tower work carefully. If possible, an observer with no other duties other than to watch for potential hazards should be positioned with a good view of the work area.

4.2.2 Antenna location

After assembling the antenna components, select a good place for it to be installed. Avoid running the antenna parallel close to power lines or telephone lines. Otherwise unwanted electrical coupling may occur, which could result in either power line noise in the station receiver or the transmitted signal appearing on the power or telephone lines. Avoid running the antenna close to metal objects, such as rain gutters, metal beams, metal siding, or even electrical wiring in the attic of a building. Metal objects may shield the antenna or modify its radiation pattern.

4.2.3 Antenna polarisation

Polarisation refers to the electrical-field characteristic of a radio wave. An antenna that is parallel to the earth's surface produces horizontally polarised radio waves. One that is perpendicular (at a 90° angle) to the Earth's surface produces vertically polarised waves.

Polarisation is most important when installing antennas for VHF or UHF. The polarisation of a terrestrial VHF or UHF signal tends not to change from transmitting antenna to receiving antenna. Both transmitting and receiving stations should use the same polarisation. Vertical polarisation is commonly used for VHF and UHF mobile operation including hand-held transceivers, in vehicles and base stations.

For HF sky-wave communications, radio signals tend to rotate through the ionosphere, thus horizontally or vertically polarised antennas can be used with almost equal results. Horizontally polarised antennas are preferred for receiving as they tend to reject local manmade noise, which is usually vertically polarised.

Vertical antennas provide low-angle radiation but have a null (radiate no energy) upward. This makes them suitable for longer sky-wave paths requiring a low take-off angle and they are not recommended for near-vertical-incidence sky-wave (NVIS) paths of about 0-500 km.

4.2.4 Tuning the antenna

The antenna length given by an equation is just an approximation. Nearby trees, buildings or large metal objects and height above ground all affect the resonant frequency of an antenna. An SWR meter can help to determine if the antenna should be shortened or lengthened. The correct length provides the best impedance match for the transmitter.

After cutting the wire to the length given by the equation, the tuning of the antenna should be adjusted for the best operation. With the antenna in its final location, the SWR should be observed at various frequencies within the desired band. If the SWR is much higher at the low-frequency end of the band the antenna is too short. If the antenna is too short, an extra length of wire can be attached to each end with an alligator clip. Then the extra length can be shortened a little at a time until the correct length is reached. If the SWR is much higher at the high-frequency end of the band, the antenna is too long. When the antenna is properly tuned, the lowest SWR values should be around the preferred operating frequency.

4.2.5 Transmission lines

The most commonly used type of antenna system transmission line is the coaxial cable ("coax"), where one conductor is inside the other. Coaxial cable has several advantages: It is readily available and resistant to weather. It can be buried in the ground if necessary, bent, coiled and run adjacent to metal with little effect.

Most common HF antennas are designed for use with transmission lines having characteristic impedances of about 50 ohms. RG-8, RG-58, RG-174 and RG-213 are commonly used coaxial cables. RG-8 and RG-213 are similar cables, and they have the least loss of the types listed here. The larger coax types (RG-8, RG-213, RG-11) have less signal loss than the smaller types. If the feed line is less than 30 meters long, the small additional signal loss on the HF bands is negligible. On VHF/UHF bands losses are more noticeable, especially when the feed line is long. On these bands, higher-quality RG-213 coax or even lower-loss rigid or semi-rigid coaxial cables minimise losses for transmission lines exceeding 30 meters.

Coaxial cable connectors are an important part of a coaxial feed line. It is prudent to check the coaxial connectors periodically to see that they are clean and tight to minimise any losses. If a bad solder connection is suspected, the joints should be cleaned and re-soldered. The choice of connectors normally depends on matching connectors on the radios. Many HF radios and many VHF radios use SO-239 connectors. The mating connector is a PL-259 (Figure 7). The PL-259 is sometimes called a UHF connector, although constant impedance connectors such as Type-N the best choice for the UHF bands. PL-259 connectors are designed for use with RG-8 or RG-213 cables. When using coax to connect the transmission line, an SO-239 connector should terminate the line at the centre insulator and a PL-259 should be used at the end connecting to the radio.

Figure 8 – PL-259 coaxial connector

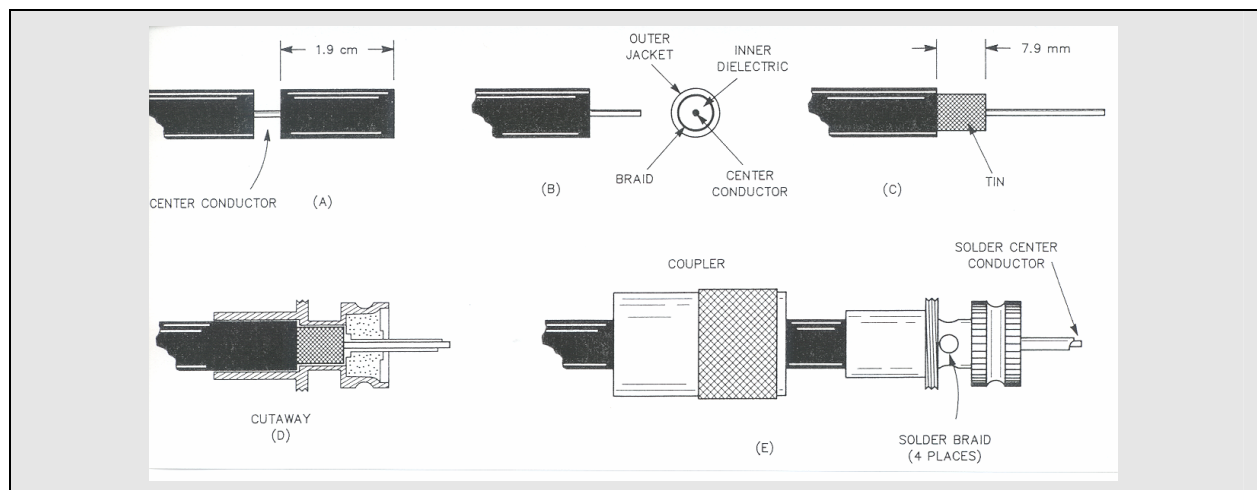

4.2.6 Matching impedances within the antenna system

If an antenna system does not match the characteristic impedance of the transmitter, some of the power is reflected back from the antenna to the transmitter. When this happens, the RF voltage and current are not uniform along the line. The power travelling from the transmitter to the antenna is called forward power and is radiated from the antenna. The standing-wave ratio (SWR) is the ratio of the maximum voltage on the line to the minimum voltage. An SWR meter measures the relative impedance match between an antenna and its feed line. Lower SWR values mean a better impedance match exists between the transmitter and the antenna system. If a perfect match exists, the SWR is 1:1. The SWR defines the quality of an antenna as seen from the transmitter, but a low SWR does not guarantee that the antenna will radiate the RF energy supplied to it by the transmitter. An SWR measurement of 2:1 indicates a fairly good impedance match.

4.2.7 SWR meters

The most common SWR meter application is tuning an antenna to resonate on a given frequency. An SWR reading of 2:1 or less is quite acceptable. A reading of 4:1 or more is unacceptable. This means there is a serious impedance mismatch between the transmitter, the antenna or the feed line.

How the SWR is measured depends on the type of meter. Some SWR meters have a SENSITIVITY control and a FORWARD-REFLECTED switch. If so, the meter scale usually provides a direct SWR reading. To use the meter, first put the switch in the FORWARD position. Then adjust the SENSITIVITY control and the transmitter power output until the meter reads full scale. Some meters have a mark on the meter face labelled SET or CAL. The meter pointer should rest on this mark. Next, set the selector switch to the REFLECTED position. This should be done without readjusting the transmitter power or the meter SENSITIVITY control. Now the meter pointer displays the SWR value. Find the resonant frequency of an antenna by connecting the meter between the feed line and your antenna. This technique will measure the relative impedance match between the antenna and its feed line. The settings that provide the lowest SWR at the operating frequency are preferred.

4.2.8 Antenna impedance matching networks

Another useful accessory is an impedance matching network. It is also called an antenna matching network, antenna tuner, antenna tuning unit (ATU), or simply a tuner. The network compensates for any impedance mismatch between the transmitter, the transmission line and the antenna. A tuner makes it possible to use one antenna on several frequency bands. The tuner is connected between the antenna and SWR meter, if used. The SWR meter is used to indicate the minimum reflected power as the tuner is adjusted.

Just one more step and the antenna installation is complete. After routing the coaxial cable to your station, cut it to length and install the proper connector for the transmitter. Usually this connector will be a PL-259, sometimes called a UHF connector. Figure 7 shows how to attach one of these fittings to RG-8 or RG-11 cable. It is important to place the coupling ring on the cable *before* installing the connector body. If using RG-58 or RG-59 cable, use an adapter to fit the cable to the connector. The SO-239 female connector is standard on many transmitters and receivers.

If the SWR is very high, a problem may exist that cannot be cured by simple tuning. A very high SWR may mean that the feed line is open or shorted. If the SWR is very high the cause may be an improper connection or insufficient space between the antenna and surrounding objects.

4.3 Practical antennas

4.3.1 The half-wave dipole antenna

Probably the most common HF antenna is a wire cut to a half wavelength ($\frac{1}{2} \lambda$) at the operating frequency. The transmission line attaches across an insulator at the centre of the wire. This is the half-wave dipole. This is often referred to as a dipole antenna. (*Di* means two, so a dipole has two equal parts. A dipole could be a length other than $\frac{1}{2} \lambda$.) The total length of a half-wavelength dipole is $\frac{1}{2} \lambda$. The feed line connects to the centre. This means that each side of this dipole is $\frac{1}{4} \lambda$ long.

Wavelength in space can be determined by dividing the constant 300 by the frequency in megahertz (MHz). For example, at 15 MHz, the wavelength is $300/15 = 20$ meters.

Radio signals travel slower in wire than in air, thus the following equation may be used to find the total length of a $\frac{1}{2} \lambda$ dipole for a specific frequency. Notice that the frequency is given in megahertz and the antenna length is in meters for this equation:

$$L \text{ (in meters)} = \frac{143}{f_{\text{MHz}}}$$

This equation also takes into account other factors, often called *antenna effects*. It gives the approximate length of wire for an HF dipole antenna. The equation will not be as accurate for VHF/UHF antennas. The element diameter is a larger percentage of the wavelength at VHF and higher frequencies. Other effects, such as *end effects* also make the equation less accurate at VHF and UHF.

Table 2 – Approximate lengths for $\frac{1}{2} \lambda$ dipoles suitable for fixed, mobile and amateur bands

| Frequency (MHz) | Length (m) | Frequency (MHz) | Length (m) | Frequency (MHz) | Length (m) |
|-----------------|------------|-----------------|------------|-----------------|------------|
| 3.3 | 43.3 | 12.2 | 11.7 | 30 | 4.8 |
| 3.5 | 40.8 | 13.4 | 10.7 | 35 | 4.1 |
| 3.8 | 37.6 | 13.9 | 10.3 | 40 | 3.6 |
| 4.5 | 31.8 | 14.2 | 10.0 | 50 | 2.86 |
| 4.9 | 29.2 | 14.6 | 9.8 | 145 | 99 cm |
| 5.2 | 27.5 | 16.0 | 8.8 | 150 | 95 |
| 5.8 | 24.6 | 17.4 | 8.2 | 155 | 92 |
| 6.8 | 21.0 | 18.1 | 7.9 | 160 | 89 |
| 7.1 | 20.1 | 20.0 | 7.1 | 165 | 87 |
| 7.7 | 18.6 | 21.2 | 6.7 | 170 | 84 |
| 9.2 | 15.5 | 21.8 | 6.5 | 435 | 33 |
| 9.9 | 14.4 | 23.8 | 6.0 | 450 | 32 |
| 10.1 | 14.1 | 24.9 | 5.7 | 455 | 31.4 |
| 10.6 | 13.5 | 25.3 | 5.6 | 460 | 31 |
| 11.5 | 12.4 | 29.0 | 4.9 | 465 | 30.7 |

Figure 9 – Construction of a simple half-wave dipole antenna. At top is the basic dipole assembly. Bottom left shows how to connect wire ends to insulators. Bottom right illustrates connection of the transmission line to the centre of the dipole

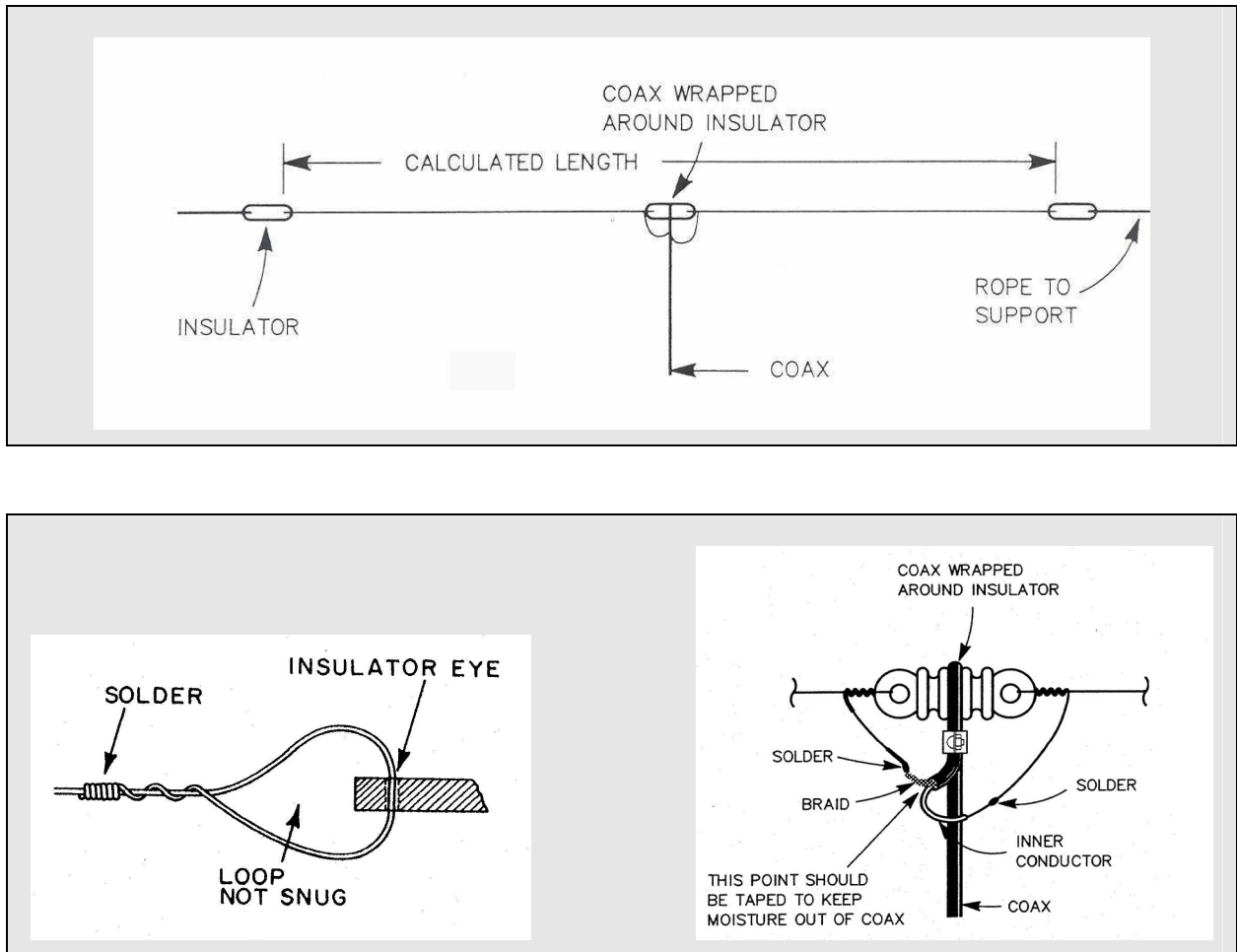

Household electrical wire and stranded wire will stretch with time; a heavy gauge copper-clad steel wire does not stretch as much. The dipole should be cut according to the dimension found by the equation above (total length of a $\frac{1}{2} \lambda$ dipole), but a little extra length should be provided to wrap the ends around the insulators. A coaxial or parallel transmission line is needed to connect the antenna to the transmitter. Three insulators are also needed. If supporting the antenna in the middle, both ends will droop toward the ground. This antenna, known as an inverted-V dipole, is almost omni-directional and works best when the angle between the wires is equal to or greater than 90° . A dipole can also be supported only at one end, in which case it is known as a sloping dipole.

Dipole antennas radiate best in a direction that is 90° to the antenna wire. For example, suppose a dipole antenna is installed so the ends of the wire run in an east/west direction. Assuming it was sufficiently above the ground (for example, $\frac{1}{2} \lambda$ high), this antenna would send stronger signals in north and south directions. A dipole also sends radio energy straight up and straight down. Of course, the dipole also emits some energy in directions off the ends of the wire, but these signals will be attenuated. Though it is possible to contact stations to the east and west with this antenna, signals are stronger with stations to the north and south.

Figure 10 – Alternative ways of installing a dipole. The configuration on the left is an Inverted-V dipole. A sloping dipole is shown at right. A balun (not shown) may be used at the feed point, as this is a balanced antenna

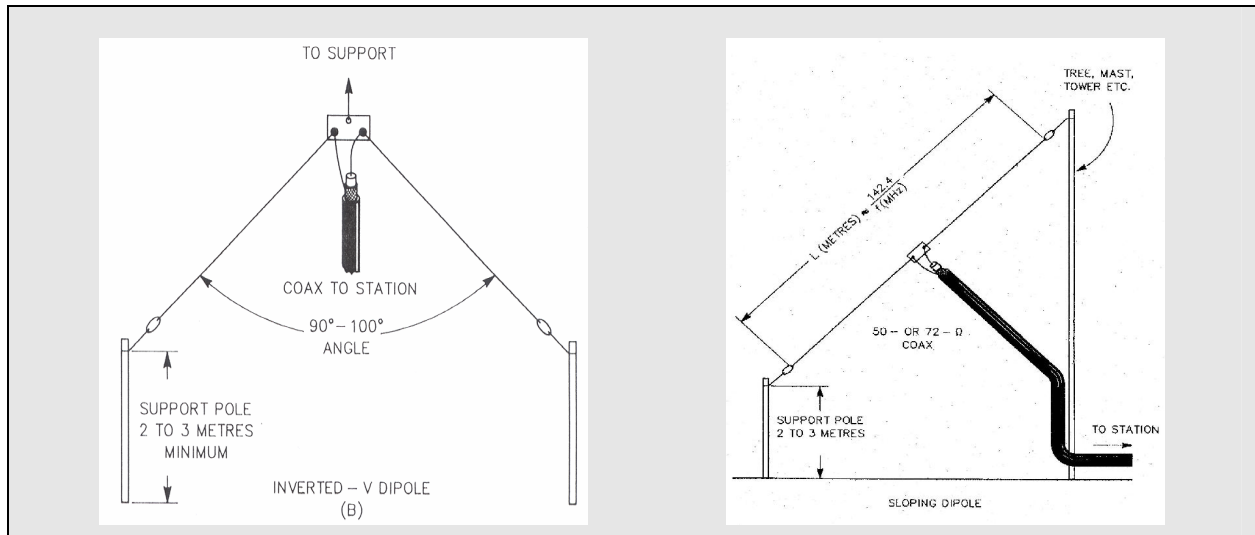

4.3.2 Broadband folded dipole

A broadband version of the dipole, the folded dipole has an impedance of about 300 ohms and can be fed directly with any length of 300 ohm feed line. This variation of the dipole is termed *broadband* because it offers a better match to the feeder over a somewhat wider range of frequencies. When a folded dipole is installed as an inverted “V” it is essentially omni-directional. There are several broadband folded dipoles available commercially that provide acceptable HF performance, even when operating without a tuner.

4.3.3 Quarter-wavelength vertical antenna

The quarter-wavelength vertical antenna is effective and easy to build. It requires only one element and one support. On the HF bands it is often used for long distance communications. Vertical antennas are referred to as non-directional or omni-directional antennas because they send radio energy equally well in all compass directions. They also tend to concentrate the signals toward the horizon as they have a low-angle radiation pattern and do not generally radiate strong signals upward.

Figure 11 shows how to construct a simple vertical antenna. This vertical antenna has a radiator that is $\frac{1}{4} \lambda$ long. Use the following equation to find the approximate length for the radiator. The frequency is given in megahertz and the length is in meters in this equation.

$$L \text{ (in meters)} = \frac{71}{f_{\text{MHz}}}$$

Figure 11 – Simple quarter-wave vertical antenna

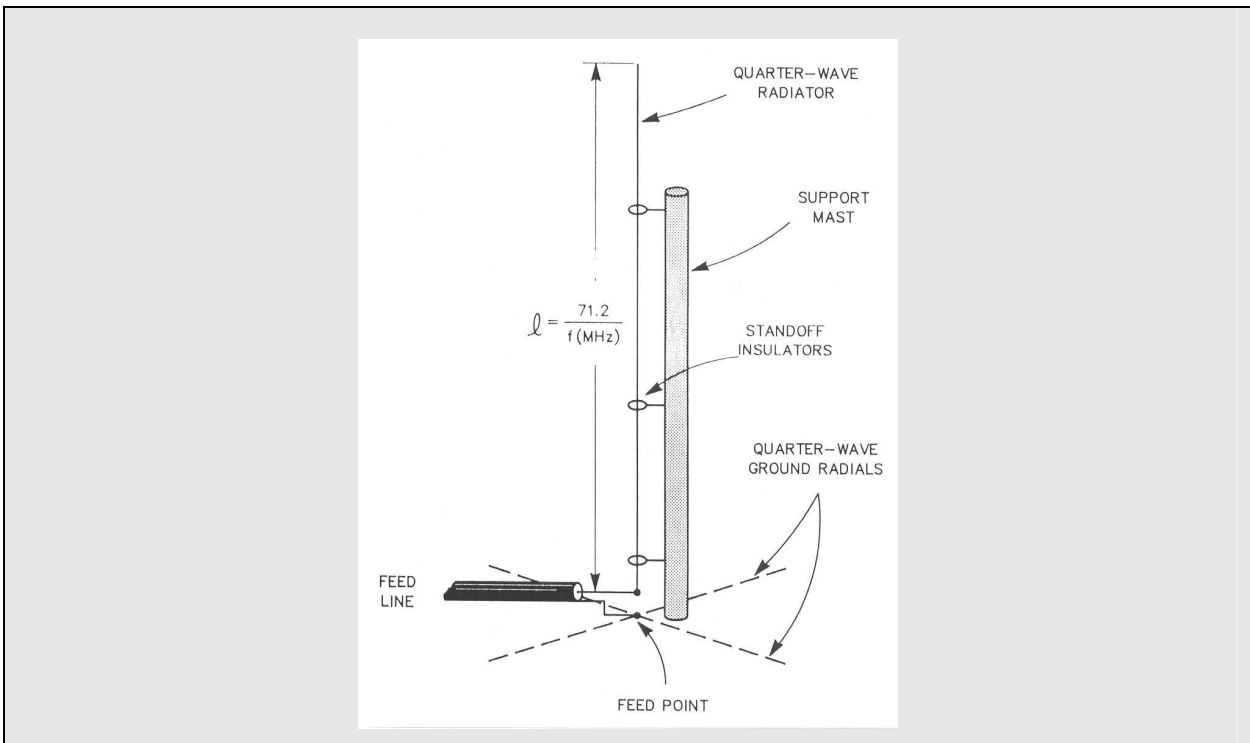

Table 3 – Approximate lengths for $\frac{1}{4} \lambda$ monopoles and ground radials suitable for fixed, mobile and amateur bands

| Frequency (MHz) | Length (m) | Frequency (MHz) | Length (m) | Frequency (MHz) | Length (m) |
|-----------------|------------|-----------------|------------|-----------------|------------|
| 3.3 | 21.6 | 12.2 | 5.9 | 30 | 2.4 |
| 3.5 | 20.4 | 13.4 | 5.3 | 35 | 2.1 |
| 3.8 | 18.8 | 13.9 | 5.1 | 40 | 1.8 |
| 4.5 | 15.9 | 14.2 | 5.0 | 50 | 1.43 |
| 4.9 | 14.6 | 14.6 | 4.9 | 145 | 50 cm |
| 5.2 | 13.7 | 16.0 | 4.5 | 150 | 48 |
| 5.8 | 12.3 | 17.4 | 4.1 | 155 | 46 |
| 6.8 | 10.5 | 18.1 | 3.9 | 160 | 44 |
| 7.1 | 10.0 | 20.0 | 3.5 | 165 | 43 |
| 7.7 | 9.3 | 21.2 | 3.3 | 170 | 42 |
| 9.2 | 7.7 | 21.8 | 3.2 | 435 | 117 |
| 9.9 | 7.2 | 23.8 | 3.0 | 450 | 16 |
| 10.1 | 7.1 | 24.9 | 2.9 | 455 | 16 |
| 10.6 | 6.7 | 25.3 | 2.8 | 460 | 16 |
| 11.5 | 6.2 | 29.0 | 2.5 | 465 | 15 |

For successful results, the $\frac{1}{4} \lambda$ vertical should have a radial system to reduce Earth losses and to act as a ground plane. For operation on high frequencies, the vertical may be at ground level and the radials placed on the ground. At least 3 radials should be used and out like the spokes of a wheel, with the vertical at the centre. Radials should be at least $\frac{1}{4} \lambda$ long or more at the lowest operating frequency.

Most vertical antennas used at HF are $\frac{1}{4} \lambda$ long or shorter with appropriate loading networks. For VHF and UHF, antennas are physically short enough that longer verticals may be used. A popular mobile antenna is a $\frac{5}{8} \lambda$ vertical, often called a “five-eighths whip”. This antenna is popular because it concentrates more of the radio energy toward the horizon than a $\frac{1}{4} \lambda$ vertical.

Commercially available vertical antennas need a coax feed line, usually with a PL-259 connector. Just as with the dipole antenna, RG-8, RG-11 or RG-58 coax can be used.

Some manufacturers offer multi-band vertical antennas that use series-tuned circuits (traps) to make the antenna resonant at different frequencies.

To fabricate a tree-mounted HF ground plane antenna (Figure 12), a length of RG-58 cable is connected to the feed point of the antenna and is attached to an insulator. The radial wires are soldered to the coax-line braid at this point. The top of the radiator section is suspended from a tree limb or other convenient support, and in turn supports the rest of the antenna.

Figure 12 – Construction of tree-mounted ground plane antenna. $L = 143/f_{\text{MHz}}$

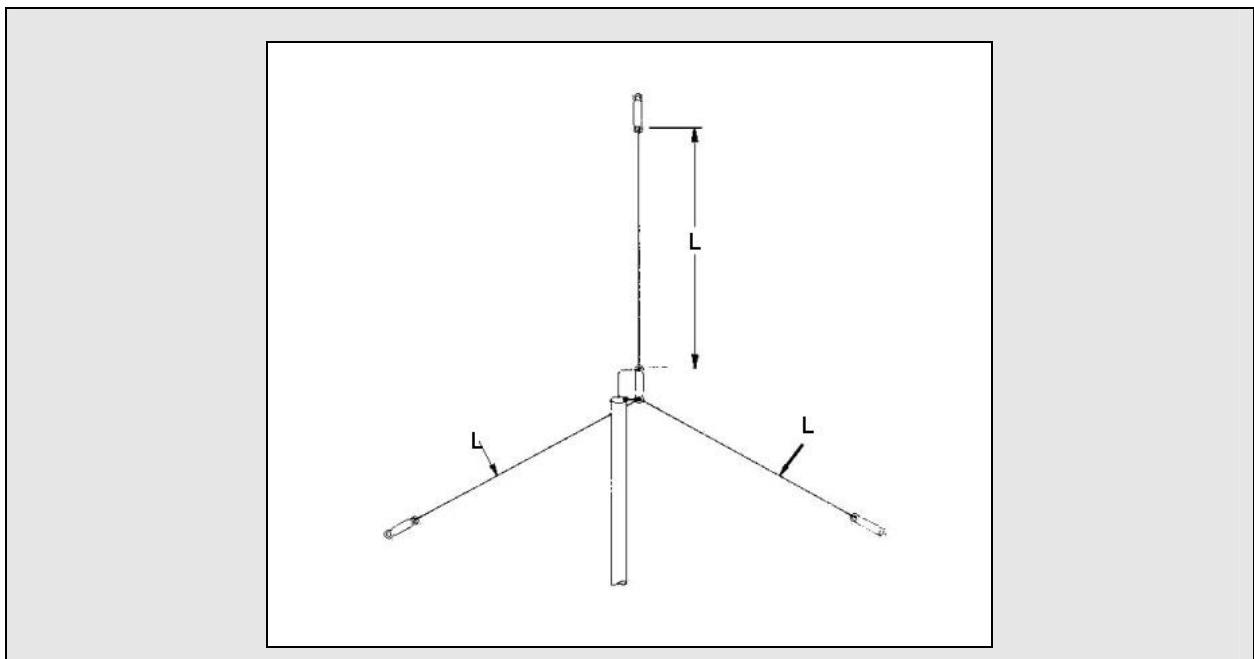

The dimensions for the antenna are the same as for a $\frac{1}{4} \lambda$ vertical antenna. All three wires of the antenna are $\frac{1}{4} \lambda$ long. This generally limits the usefulness of the antenna to 7 MHz and higher bands, as temporary supports higher than 10 or 15 meters may not be available.

4.3.4 Antennas for hand-held transceivers

VHF and UHF hand-held transceivers normally use shortened flexible antennas that are inexpensive, small, lightweight and robust. On the other hand, they have some disadvantages: It is a compromise design that is inefficient and thus does not perform as well as larger antennas. Two better-performing antennas are the $\frac{1}{4} \lambda$ and the $\frac{5}{8} \lambda$ telescoping types that are available as separate accessories.

4.3.5 Vertical antennas for VHF and UHF

For operation of stations at fixed locations, the $\frac{1}{4} \lambda$ vertical is an ideal choice. The 145 MHz model shown in Figure 13 uses a flat piece of sheet aluminium, to which radials are connected with machine screws. A 45° bend is made in each of the radials. This bend can be made with an ordinary bench vise. An SO-239 chassis connector is mounted at the centre of the aluminium plate with the threaded part of the connector facing down. The vertical portion of the antenna is made of 10 mm copper wire soldered directly to the centre pin of the SO-239 connector.

Figure 13 – A VHF or UHF ground plane antenna with 4 drooping radials. $L = 143/f_{\text{MHz}}$

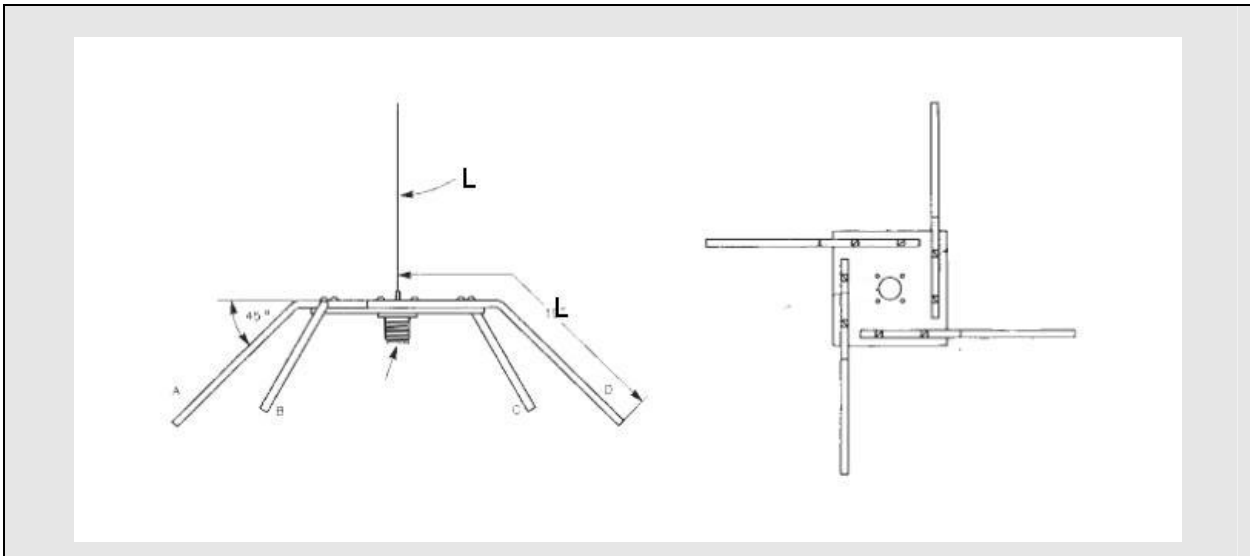

Construction is simple as it requires nothing more than an SO-239 connector and some common hardware. A small loop formed at the inside end of each radial is used to attach the radial directly to the mounting holes of the coaxial connector. After the radial is fastened to the SO-239 with hardware, a large soldering iron or propane torch is used to solder the radial and the mounting hardware to the coaxial connector. The radials are bent to a 45° angle and the vertical portion is soldered to the centre pin to complete the antenna. It is prudent to apply a small amount of sealant around the areas of the centre pin of the connector to prevent the entry of water into the connector and coax line.

4.3.6 Delta loop

The Delta loop is another field expedient wire antenna used by disaster relief organisations. There are three key advantages to a Delta loop antenna: 1) a ground plane is unnecessary; 2) a full-wave loop (depending on the shape) has some gain over a dipole; and 3) a closed loop is a “quieter” (improved signal-to-noise ratio) receiving antenna than are most vertical and some horizontal antennas. Feed point selection will permit the choice of vertical or horizontal polarisation. Various angles of radiation will result from assorted feed-point selections. The system is rather flexible and is capable of maximising close in or long distance communications (high angle versus low angle). Figure 14 illustrates various configurations that can be used. The bandwidth at resonance is similar to a dipole. An antenna-tuning unit (ATU) is recommended for matching the system to the transmitter in parts of the band where the SWR is high. There is no rule that dictates the shape of a full wave loop. It may be convenient to use a triangular shape with the apex is at the top in which case only one high support is needed. Circular, square or rectangular shapes have been used.

Figure 14 – Various configurations for a full-wavelength Delta loop antenna. Overall length of the antenna wire is approximately $286/f_{\text{MHz}}$

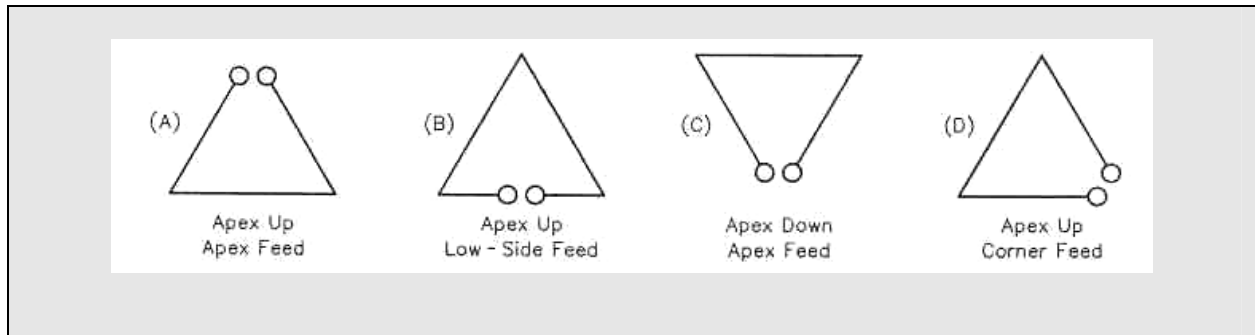

| Configuration | A | B | C | D |
|-----------------|-----------------|------------|-----------------|----------|
| Polarisation | Horizontal | Horizontal | Horizontal | Vertical |
| Radiation angle | Moderately high | High | Moderately high | Low |

4.3.7 Directional antennas

Directional antennas have two important advantages over simpler omni-directional antennas such as dipoles and vertical monopoles. As transmitting antennas, they concentrate most of the radiation in one direction. For receiving, directional antennas can be pointed toward the desired direction or away from a source of noise.

Although generally large and expensive below about 10 MHz, directional antennas often are used on the upper high frequency bands, such as from 10 MHz to 30 MHz. Directional antennas commonly used at VHF and UHF owing to their reasonably small size. The most common directional antenna is the *Yagi* antenna, but there are other types, as well.

A Yagi antenna has several elements attached to a central *boom*, as Figure 15 shows. The elements are parallel to each other and are placed in a straight line along the boom. Although several factors affect the amount of gain of a Yagi antenna, *boom length* has the largest effect: The longer the boom, the higher the gain.

The transmission line connects only to one element called the *driven element*. On a three-element Yagi like the one shown in Figure 15, the driven element is in the middle. The element at the front of the antenna (toward the favoured direction) is a director. Behind the driven element is the reflector element. The driven element is about $\frac{1}{2} \lambda$ long at the antenna design frequency. The director is a bit shorter than $\frac{1}{2} \lambda$, and the reflector a bit longer. Yagi beams can have more than three elements, usually by adding more directors. Directors and reflectors are called parasitic elements, since they are not fed directly.

Communication in different directions may be achieved by turning the array using a rotator in the azimuthal (horizontal) plane, to point it in different directions.

Figure 15 – A three-element Yagi showing the reflector, driven element and director supported by a boom

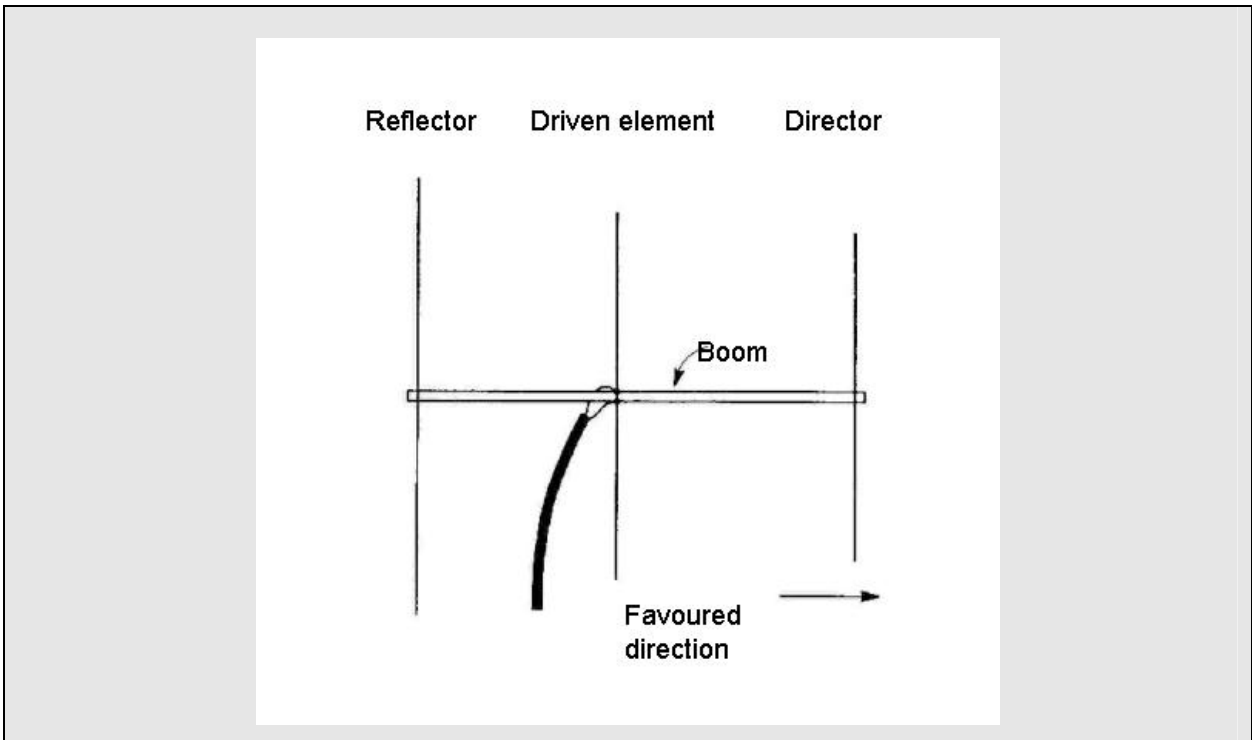

4.3.7.1 Log-periodic arrays

Log-periodic antennas are an alternative directional antenna. They have wider bandwidth but lower directional gain than a Yagi.

A log-periodic antenna is a system of driven elements, designed for operation over a wide range of frequencies. Its advantage is that it exhibits essentially constant characteristics over the frequency range – the same radiation resistance (and therefore the same SWR), and the same pattern characteristics (approximately the same gain and the same front-to-back ratio).

5 Power sources and batteries

5.1 Power safety

As in antenna work, for safety purposes any electrical work should be done with a second person present. A switch should never be used in the neutral wire without also disconnect the equipment from an active or “hot” line.

All communications equipment should be reliably connected to an Earth ground by means of a separate heavy gauge wire. The power wiring neutral conductor should not be used for this safety ground. This places the chassis of the equipment at Earth ground potential for minimal RF energy on the chassis. It provides a measure of safety for the operator in the event of accidental short or leakage of one side of the power line to the chassis.

No battery should be subjected to unnecessary heat, vibration or physical shock. The battery should be kept clean. Frequent inspection of leaks is recommended. Electrolyte that has leaked or sprayed from the battery should be cleaned from all surfaces. The electrolyte is chemically active and electrically conductive, and may ruin electrical equipment. Acid may be neutralized with sodium bicarbonate (baking soda), and alkalis may be neutralized with a weak acid such as vinegar. Both neutralizers will dissolve in water, and should be quickly washed off. The neutralizer should not be allowed to enter the battery. Gas escaping from storage batteries may be explosive. Keep flames or lighted tobacco products away.

When working with generators, keep safety foremost in your mind. Gasoline is a dangerous chemical and there is no scope for carelessness. Fuel should be stored only in the proper containers, well away from the generator and out of the sun. The generator should be turned off and cool before adding new fuel. Gasoline and oil-soaked rags should be disposed of properly. If they are tossed in a pile, they could catch fire by spontaneous combustion. A fire extinguisher should be kept near the generator. Smoking should not be allowed near the generator.

Internal combustion engines produce heat. The larger the engine, the higher the speed, the greater the heat produced. The combination of fuel fumes and engine heat in a small enclosure is dangerous. Generator exhaust fumes can be lethal. Whether gasoline, diesel, natural gas or propane is used, be sure that exhaust fumes are properly vented out of the operating area. Natural ventilation is usually not sufficient to maintain a safe atmosphere. A blower or ventilator fan should be used to bring fresh air from outside, with an exhaust fan installed to expel the heat.

5.2 Mains power

Mains power should be used when available to save any self-generated power systems for backup purposes. Even unreliable mains power can be used to charge batteries.

Electrical service enters buildings in the form of two or more wires to provide 100-130 V or 200-260 V alternating current at 50 or 60 Hz. The circuits may be divided into several branches and protected by circuit breakers or fuses.

A ground fault circuit interrupter (GFCI or GFI) is also desirable to safety reasons, and should be a part of the electrical power wiring if possible.

5.3 Power transformers

Numerous factors should be considered in selecting transformers, such as input and output volt-ampere (VA) ratings, ambient temperature, duty cycle and mechanical design.

In alternating-current equipment, the term “volt-ampere” is often used rather than the term “watt”. This is because ac components must handle reactive power as well as real power. The number of volt-amperes delivered by a transformer depends not only upon the dc load requirements, but also upon the type of dc output filter used (capacitor or choke input), and the type of rectifier used (full-wave centre tap or full-wave bridge). With a capacitive-input filter, the heating effect in the secondary is higher because of the high peak-to-average current ratio. The volt-amperes handled by the transformer may be several times the power delivered to the load. The primary winding volt-amperes will be somewhat higher because of transformer losses.

A transformer operates by producing a magnetic field in its core and windings. The intensity of this field varies directly with the instantaneous voltage applied to the transformer primary winding. These variations, coupled to the secondary windings, produce the desired output voltage. Since the transformer appears to the source as an inductance in parallel with the (equivalent) load, the primary will appear as a short circuit if dc is applied to it. The unloaded inductance of the primary must be high enough so as not to draw an excess amount of input current at the design line frequency (normally 50 or 60 Hz). This is achieved by providing sufficient turns on the primary and enough magnetic core materials so that the core does not saturate during each half-cycle.

To avoid possibly serious overheating, transformers and other electromagnetic equipment designed for 60 Hz systems must not be used on 50 Hz power systems unless specifically designed to handle the lower frequency.

5.4 Batteries and charging

The availability of solid-state equipment makes it practical to use battery power under portable or emergency conditions. Hand-held transceivers and instruments are obvious applications, but 100 W output transceivers may be practical users of battery power (for example, emergency power for HF transceivers).

Low-power equipment can be powered from two types of batteries. The *primary* battery is intended for one-time use and is then discarded; the *storage* (or *secondary*) battery may be recharged many times.

A battery is a group of chemical cells, usually connected in series to give some desired multiple of the cell voltage. Each assortment of chemicals used in the cell gives a particular nominal voltage. This must be taken into account to make up a particular battery voltage. For example, four 1.5 V carbon-zinc cells make a 6 V battery and six 2 V lead-acid cells make a 12 V battery.

5.4.1 Battery capacity

The common rating of battery capacity is ampere-hours (Ah), the product of discharge current and time. The symbol C is commonly used; $C/10$, for example, would be the current available for 10 hours continuously. The value of C changes with the discharge rate and might be 110 at 2 A but only 80 at 20 A. Capacity may vary from 35 mAh for some of the small hearing aid batteries to more than 100 Ah for a size 28 deep-cycle storage battery.

Sealed primary cells usually benefit from intermittent (rather than continuous) use. The resting period allows completion of chemical reactions needed to dispose of by-products of the discharge.

The output voltage of all batteries drops as they discharge. “Discharged” condition for a 12 V lead-acid battery, for instance, should not be less than 10.5 V. It is also good to keep a running record of hydrometer readings, but the conventional readings of 1.265 charged and 1.100 discharged apply only to a long, low-rate discharge. Heavy loads may discharge the battery with little reduction in the hydrometer reading.

Batteries that become cold have less of their charge available, and some attempt to keep a battery warm before use is worthwhile. A battery may lose 70% or more of its capacity at cold extremes, but it will recover with warmth. All batteries have some tendency to freeze, but those with full charges are less susceptible. A fully charged lead-acid battery is safe to -26°C or colder. Storage batteries may be warmed somewhat by charging or discharging. Blow touches or other flame should never be used to heat any type of battery.

A practical discharge limit occurs when the load will no longer operate satisfactorily on the lower output voltage near the “discharged” point. Much gear intended for “mobile” use may be designed for an average of 13.6 V and a peak of perhaps 15 V, but will not operate well below 12 V. For full use of battery charge, the gear should operate well (if not at full power) on as little as 10.5 V with a nominal 12 to 13.6 V rating.

Somewhat the same condition may be seen in the replacement of carbon-zinc cells by NiCd storage cells. Eight carbon-zinc cells will give 12 V, while 10 for the same voltage. If a 10-cell battery holder is used, the equipment should be designed for 15 V in case the carbon-zinc units are plugged in.

5.4.2 Primary batteries

One of the most common primary-cell types is the alkaline cell, in which chemical oxidation occurs during discharges. When there is no current, the oxidation essentially stops until current is required. A slight amount of chemical action does continue, however, so stored batteries eventually will degrade to the point where the battery will no longer supply the desired current.

The alkaline battery has a nominal voltage of 1.5 V. Larger cells capable of production more milliampere hours and less voltage drop than smaller cells. Heavy duty and industrial batteries usually have longer shelf life.

Lithium primary batteries have a nominal voltage of about 3 V per cell and by far the best capacity, discharge, shelf life and temperature characteristics. Their disadvantages are high cost and that they cannot be readily replaced by other types in an emergency.

The lithium-thionyl-chloride battery is a primary cell and should not be recharged under any circumstances. The charging process vents hydrogen, and a catastrophic explosion can result. Even accidental charging caused by wiring errors or a short circuit should be avoided.

Silver oxide (1.5 V) and mercury (1.4 V) batteries are used where nearly constant voltage is desired at low currents for long periods. Their primary application is in small equipment.

Primary batteries should not be recharged for two reasons: It may be dangerous because of heat generated within sealed cells, and even in cases where there may be some success, both the charge and life are limited. One type of alkaline battery is rechargeable and is so marked.

5.4.3 Secondary batteries

The most common type of small rechargeable battery is the nickel-cadmium (NiCd), with a nominal voltage of 1.2 V per cell. Carefully used, these are capable of 500 or more charge/discharge cycles. For long life, the NiCd battery should not be fully discharged. Where there is more than one cell in the battery, the most-discharged cell may suffer polarity reversal, resulting in a short circuit or seal rupture. All storage batteries have discharge limits, and NiCd types should not be discharged to less

than 1.0 V per cell. Nickel cadmium cells are not limited to “D” size and smaller cells. They also are available in large varieties ranging to mammoth 1 000 Ah units having carrying handles on the sides and top for adding water, similar to lead-acid types. They are used extensively for uninterruptible power supplies.

For high capacity, the most widely used rechargeable battery is the lead-acid type. In automotive service, the battery is usually expected to discharge partially at a very high rate and then to be recharged promptly while the alternator is also carrying the electrical load. The most appropriate battery for extended high-power electronic applications is the so-called “deep-cycle” battery. These batteries may furnish between 1 000 and 1 200 Wh per charge at room temperature. When properly cared for, they may be expected to last more than 200 cycles. They often have lifting handles and screw terminals, as well as the conventional truncated cone automotive terminals. They may also be fitted with accessories, such as plastic carrying cases, with or without built-in chargers. Lead-acid batteries are also available with gelled electrolyte. Commonly called “gel cells”, these may be mounted in any position sensitive.

An automotive lead-acid battery was designed for one task: to deliver a lot of current for a brief period of time. Its output voltage does not remain constant during its discharge cycle, and it is not a good idea to discharge it completely. An automobile battery will not tolerate too many deep-discharge cycles before it's ruined.

A deep-discharge lead-acid battery is much better suited emergency power needs. It can be discharged repeatedly without damage, and will maintain full output voltage over much of its discharge cycle. This type of battery is available at automobile- and marine-parts supply outlets. They are not much more expensive than regular automobile batteries and are designed to deliver moderate current for long periods of time.

The nickel metal hydride (NiMH) battery is similar to the NiCd, but the cadmium electrode is replaced by one made from a porous metal alloy that traps hydrogen; therefore the name of metal hydride. Many of the basic characteristics of these cells are similar to NiCds. For example, the voltage is very nearly the same, they can be slow-charged from a constant current source and they can safely be deep cycled. There are also some important differences: They have higher capacity for the same cell size often nearly twice as much as the NiCd types. The typical size AA NiMH cell has a capacity between 1 000 and 1 300 mAh, compared to the 600 to 830 mAh for the same size NiCd. Another advantage of these cells is a complete freedom from memory effect. NiMH cells do not contain any dangerous substance, while both NiCd and lead-acid cells do contain quantities of toxic heavy metals.

The Lithium-ion (Li-ion) cell is another possible alternative to the NiCd cell. For the same energy storage, it has about one third the weight and one half the volume of NiCd. It also has a lower self-discharge rate. Typically, at room temperature, a NiCd cell will lose from 0.5 to 2% of its charge per day. The lithium-ion cell will lose less than 0.5% per day and even this loss rate decreased after about 10% of the charge has been lost. At higher temperature the difference is even greater. The results are that Lithium-ion cells are a better choice for standby operation where frequent recharge is not available. One major difference between NiCd and Li-ion cells is the cell voltage. The nominal voltage for NiCd cell is about 1.2 V. For the Li-ion cell it is 3.6 V with a maximum cell charging voltage of 4 V. Li-ion cells cannot be substituted directly for NiCd cells. Chargers intended for NiCd batteries must not be used with Li-ion batteries, and vice versa.

5.5 Inverters

One source of ac power for use in the field is a dc-to-ac converter, or more commonly, an inverter. The ac output of an inverter is a usually square wave. Therefore, some types of equipment cannot be operated from the inverter. Certain types of motor are among those devices that require a sine-wave output. Aside

from having a square-wave output, inverters have some other traits that make them less than desirable for field use. Commonly available models do not provide a high power handling capability. Higher power models are available but are quite expensive.

5.6 Generators

For long-term emergency operation, a generator is a requirement. The generator will provide power as long as fuel is available. Proper care is necessary to keep the generator operating reliably, however.

For these periods when the generator is shut down, battery power can be used until the generator can be reactivated. The lubricating oil level should be checked periodically.

If the oil sump becomes empty, the engine can seize, putting the station out of operation and necessitating costly engine repairs.

Remember the engine will produce carbon monoxide gas while it is running. The generator should never run indoors and should be placed away from open windows and doors to keep exhaust fumes from coming inside.

Generators in the 3-5 kW range are easily handled by two people and can provide power for radios and other electrical equipment. Most generators provide 12 V dc output in addition to 120/240 V ac.

Some generators have a continuous power rating and an intermittent power rating. If the total station requirement exceeds the available generator power, transceivers draw full power only while transmitting and that they are not going to be transmitting 100% of the time. It is necessary to ensure that the total possible power consumption does not exceed the intermittent power rating of the generator.

Generators should be tested regularly. Fuel should be fresh. Operator level maintenance (tune-up or oil change) should be performed regularly. Spark plugs should be checked carefully and spare spark plugs should be maintained. The air cleaners should be checked and cleaned according to manufacturer's instructions.

The generator should be checked for proper operation. If there are any fuel leaks, it should be turned off immediately and the problem corrected. The muffler should be inspected. All protective covers should be in place. The output voltage should be tested. If the generator does not have a built-in over-voltage protector, the voltage should be correct before applying power to radio equipment.

Finally, the generator should be checked for radio noise. Some generators are not fully suppressed for ignition noise. If there is a problem, it may be possible to use resistor-type spark plugs or spark-plug wires. A good Earth ground with a ground rod may help minimize noise.

5.6.1 Installation considerations

Any internal combustion engine is noisy and bothersome when communication equipment is being operated nearby. The placement of a power plant is important, regardless of its size. An engine running at 3 600 rotations per minute, even with an efficient muffler system produces noise and vibration. The engine vibrations are conducted through the base upon which the engine is mounted to the ground or walls of the building housing the system. Brick or concrete-block construction will

reduce the noise level, but if the generator shack is metal, there is less noise abatement. Metal panels may vibrate in sympathy with the sound source add to the din. Applying a hardening caulking compound to the vertical edges of the metal panels can eliminate some of the noise, as can the use of sound-deadening material in lining the shack.

The distance between the alternator and the operating must be considered. Sound intensity varies inversely with the square of the distance from the source. The noise at a distance of 20 meters will be one-fourth that at a distance of 10 meters. At 30 meters, it will be one ninth.

Fuel consumption must be considered, both from an installation aspect and as a safety problem. Fuel will be used at the rate of 2 to 4 litres per hour is a 2.5-5 kW generator. There should be an ample reserve plan of at least 48 hours of operation. If the fuel is gasoline, safe storage can be a problem. Store gasoline in an area separate from the area housing the generator. Transfer only enough fuel at one time to fill the power unit's tank. If you in an area where propane or natural gas are available, it might be worthwhile to consider these options as a fuel source. Some alternators are supplied with multiple-fuel capabilities (gasoline or natural gas/propane). A special carburetion system is required for natural gas or propane.

5.6.2 Generator maintenance

Proper maintenance is necessary to obtain rated output and long service life from a gasoline generator. A number of simple measures will prolong the life of the equipment and help maintain reliability.

The manufacturer's manual should be the primary source of maintenance information and the final word on operating procedures and safety. The manual should be thoroughly covered by all persons who will operate and maintain the unit.

Fuel should be clean, fresh and of good quality. Many problems with gasoline generators are caused by fuel problems. Examples include dirt or water in the fuel and old, stale fuel. Gasoline stored for any length of time changes as the more volatile components evaporate. This leaves excess amount of varnish-like substances that will clog carburetor passages. If the generator will be stored for a long period, it is good to run it until all of the fuel is burned. Faulty spark plugs are a common cause of ignition problems. Spare spark plugs should be kept with the unit, along with tools needed to change them.

5.6.3 Generator earth ground

A proper ground for the generator is necessary for both safety reasons and to ensure proper operation of equipment powered from the unit. Most generators are supplied with a three-wire outlet. Some generators require that the frame be grounded also. An adequate pipe or rod should be driven into the ground near the generator and connected to the provided clamp or lug.

5.7 Solar power

A solar cell is a very simple semiconductor. Solar cells are, in fact, large-area semiconductor diodes. Simply explained, when the photons contained in light rays bombard the barrier of this semiconductor, hole electron pairs inside this P-N junction are freed, resulting in a forward bias of the junction, just as in phototransistors. This forward-biased junction can deliver current into a load. Because the exposed area of a solar cell can be quite large, the forward current produced can be substantial. It follows that the output current of a photocell is directly proportional to the rate of photon bombardment, and thus to the exposed area of the photocell.

5.7.1 Types of solar cells

Originally, solar cells were made by cutting slides of grown silicon-crystal rod and subjecting them to doping and metallization process. These solar cells are called monocrystalline cells because each unit consists of only one crystal plate. The shape of these cells is the same as that of the silicon rod from which they are cut: round. A slice of this material with an area of 50 mm can be made into one photocell, but a slice of this size could also be used to produce upwards of a thousands transistors.

Most are polarity protected with a diode in series with the positive voltage line. When it gets dark, and the output voltage drops, the diode ensures that the panel won't start drawing current from the battery.

Solar panels typically deliver 15 to 18 V at 600 to 1 500 mA in full sunlight. This will not damage a high-capacity battery, such as a deep-cycle unit. All you need do is hook up the battery, put the solar panel in full sunlight, and charge away. The battery will regulate the maximum voltage from the panel.

If you're going to use a solar panel to recharge a smaller battery, such as a Nickel-Cadmium (NiCd) battery or gelled-electrolyte lead-acid battery, you'll need to pay a bit more attention to detail. These types of batteries can suffer damage if charged too quickly, so a regulated charge is necessary.

A dc-ac converter, or inverter converts 12 V to a square-wave ac output at approximately 60 Hz. Inverters are limited to about 100 to 400 watts, however, and some equipment (especially motors) cannot be powered by a square wave. An inverter will run a few light bulbs or a small soldering iron and can be a useful addition to a battery-operated station. Some newer ones use switching technology and are quite lightweight.

Polycrystalline cells are typically manufactures as rectangular blocks of seemingly randomly arranged silicon crystals from which the cell plates are cut. These cells are recognized by their shape, random pattern and colourful surface. Polycrystalline cells are less expensive to manufacture than monocrystalline cells. Reliable amorphous panels are available from many manufactures. These panels come in several forms: mounted on thin glass, framed, and even mounted on flexible substrates, such as steel.

5.7.2 Solar cell specifications

Depending on construction, each cell has an open-circuit, when exposed to the sun, of 0.6 to 0.8 V. This output voltage drops somewhat when current is drawn from a solar cell. This is called the cell's *load curve*. Open-circuit voltage is approximately 0.7, and output voltage at optimum load is normally 0.45. Output current is maximum with shorted output terminals. This maximum current is called the short-circuit current, and is dependent on the cell type and size. Because a cell's output current remains relatively constant under varying load conditions, it can be considered to be a constant-current sources.

As with batteries, solar cells may be operated in series to increase output voltage, and/or in parallel to increase output-current capability. Several manufactures supply arrays or panels with a number of cells in a series-parallel hook-up to be used, for example, for battery charging.

Techniques have been developed for the construction of amorphous cells whereby the cells are manufactured in series by cutting metal layers that have been vapour deposited on the amorphous silicon mass. This cutting is done with a laser. Cell width is such panels may be up to several feet, and the output-current capability of these relatively economical panels is excellent.

Solar-cell efficiency varies: Monocrystalline cell have efficiencies up to 15%; polycrystalline cells, 10 to 12%; amorphous cells, 6.5 to over 10%, depending on the manufactures process.

The output power of solar arrays or panels is specified in watts. Typically, the listed wattage is measured at full exposure to sunlight, at a nominal potential of 7 V for a 6-V system, 14 V for a 12-V system, and so on. You can calculate the maximum current that can be expected from a solar panel by dividing the specified output power by the panel voltage.

5.7.3 Storing solar energy

Because the sun does not shine 24 hours per day at many locations, some means of storing collected energy must be used. Batteries are commonly used for this purpose. Battery capacity is generally expressed in ampere-hours (Ah) or milliampere-hours (mAh). This rating is simply the product of discharge current and discharge time in hours. For example, a fully charge 500-mAh NiCd battery of good quality can deliver a discharge current of 100 mA for a period of 5 hours, or 200 mA for 2½ hours before recharging is required. Three types of rechargeable batteries are commonly used:

Nickel-cadmium (NiCd) batteries: NiCd are mostly used in relatively low energy applications such as hand-held transceivers, scanners, etc. The development of consumer electronics has contributed to the rapidly increasing availability (and somewhat-less-rapidly decreasing cost) of NiCd. Major advantage of NiCd: They are hermetically sealed, operate in any position and have a good service life (several hundred charge/discharge cycles), if they are properly maintained.

Gelled-electrolyte lead-acid batteries: These hermetically sealed batteries are available in capacities from below 1 Ah to more than 50 Ah. They are ideal for supplying energy to a radio station, but their cost (for capacities above 10 Ah) is rather high. For portable and low power stations, thought, this type of battery is difficult to beat. The cells can be operated in any position, but should be charged in an upright position. If properly maintained (no deep discharges-cell polarity reversal is possible under these conditions-and they stored in a fully charged state), gel cells last a long time (500 or so cycles).

Other lead-acid batteries: These are available in the standard automotive version, in the marine/recreational vehicle deep-discharge version and in the golf-cart variety. Differences: Automotive batteries usually fail (because of the thin plate and insulation material used in their construction), resulting in premature internal short circuits. Golf-cart and marine/recreational vehicle batteries have thicker plated with more rigid insulation between them, so these batteries can with stand deeper discharge without plate deformation and internal failure. Deep discharge batteries provide the best value in a ham station. Some of these batteries require attention (the electrolyte level must be maintained), and they last longest when kept charged. Because these batteries use a wet electrolyte (water), and most of them are not hermetically sealed, they must be kept upright.

5.7.4 A typical application

Here's a practical example of how to calculate power requirements for a solar-powered HF radio station. The first thing to do is define the power demand. Assume a 100-W transmitter. The assumption is that 100 W is the peak power consumption, and occurs only during CW operation and SSB voice peaks when a 13.6-V nominal supply (a fully charged battery) is provided.

The most reliable way to calculate realistic power requirements is to determine the power used over a longer period of time (say) a week or month. Because most of us have more or less recurring weekly habits, we'll take one week as the base period. (One can substitute numbers to adapt this calculation for the transmitter, under typical operating circumstances.) Assume that the transmitter is turned on five days. Of each two-hour period, 1½ hours is spent listening, and transmitting takes the remaining

half hour. Assume that the current consumption of the transceiver during receive is 2 A; during the 100-W peaks on transmit, current drawn is 20 A. The owner's manual for transmitter should give the maximum dc current drain. The average current consumption during SSB transmitting is only about 4 A. Therefore, we need a battery that can supply a peak current of at least 20 A and an average current of 4 A. Now calculate the total energy consumed in ampere hours over a one-week period:

Receiving: $2 \text{ A} \times 2\frac{1}{2} \text{ hours/day} \times 5 \text{ days} = 25 \text{ Ah}$

Transmitting: $4 \text{ A} \times \frac{1}{2} \text{ hours/day} \times 5 \text{ days} = 10 \text{ Ah}$

The total energy used per week is $25 + 10 = 35 \text{ Ah}$, or per day (average) is $35 \div 7 = 5 \text{ Ah}$. If we had a perfect system, all we would need to do is supply 35 Ah per week (5 Ah per day) to the battery. In practice, imperfections in battery construction cause some loss (self discharge), for which the charging system must compensate.

Next, calculate the minimum battery capacity required for this application. The system should be designed so that sufficient energy is available to run the equipment for two consecutive sunless days (this is rather arbitrary – some locations are worse than others in this regard). Because these sun less days could be days on which operation is necessary and because it is not good to discharge a battery to less than 50% of its capacity (for maximum battery life), this battery must have a capacity of least $2 \text{ (days)} \times 5 \text{ Ah} \div 0.5$ (for the 50% charge capacity left after 3 days without sunshine) = 20 Ah. If the location is likely to be without sunshine for as much as an entire week, the battery requirement would be $7 \times 5 \div 0.5 = 70 \text{ Ah}$. Add about 10% to this number to compensate for self-discharge and other losses. (Typically, this means to procure the next-larger-size battery than the initial calculations indicated.)

To keep the battery sufficiently charged, firstly estimate the average number of hours of sunshine per year in the area. This information can be found in an almanac. As a guide, average annual sun exposure is approximately 3 200 hours per year in sunny regions, less elsewhere (down to about 1 920 hours per year in the far northern climates).

The solar panel should be mounted in a fixed position with an optimum angle relative to the Earth. In temperate zones, it could vary from about 30° in the summer up to about 60° in winter. Fixed-mounted solar panels cannot pick up maximum energy from the sun, for obvious reasons. In practice, they receive only 70% of the total sunlit time, which is anywhere between 1 340 and 2 240 hours per year (between 26 and 43 hours per week), depending on location.

The remaining system planning is easy. Earlier calculations showed that the solar cells must replenish 35 Ah per week, plus 10% to compensate for losses, or about 38.5 Ah or battery capacity. With solar energy available in the Sunbelt for 43 hours per week, the required charge current is $38.5 \text{ Ah} \div 43 \text{ hours of sunshine} = 0.9 \text{ A}$. In the northern part of the US, this is $38.5 \text{ Ah} \div 25.8 \text{ hours} = 1.5 \text{ A}$.

In the 12-V system described here, the solar panel operates, with a fully charged battery at about 13.6 V, plus the voltage drop of a series diode. With a fully loaded panel voltage of 14 V, a panel rated at 21 W ($14 \text{ V} \times 1.5 \text{ A}$) is required in northern climes. In practice, this power can be obtain from good quality solar panel with a surface area as small as 65 cm². In sunny regions only 12.6 W ($14 \text{ V} \times 0.9 \text{ A}$) of solar energy may be needed.

5.7.5 Some practical hints

Solar panels can be wired in series to provide increased output voltage. If the total output of the cell array exceeds 20 V, shunt diodes may be wired across each solar cells. Similarly, solar panels can be wired in parallel to yield increased output-current capability.

A series diode should be installed to prevent discharge of the battery into the panels. A Schottky diode can be used in applications where it is important to maintain the lowest voltage drop (and minimum loss of charge current).

Precaution should be taken to prevent battery overcharging and related gas discharge inside the battery. Several manufacturers supply simple charge regulators that serve this purpose by disconnecting the solar panel from the battery when the battery is fully charged. Some of these chargers allow charging to resume when the battery has reached a measurable level of discharge.

Note: These values are only valid for lead-acid batteries; and entirely different set of charge criteria exists for NiCds.

5.7.6 Installing solar panels

If you plan to permanently install solar panels, consider mounting them at ground level on a simple wooden or metal frame, or mounting them on the roof. Roof mounting is more appropriate if you have a roof that slopes at the correct angle (30-60°), and in the right direction (anywhere between a little east of south and southwest is acceptable). The easiest way to mount panels permanently is with a silicone adhesive. First, series diodes should be mounted on the back of each panel.

If the solar panels are going to be located in an area where they might be subjected to lightning, it is especially important to ground the metal frames of the solar panels. A separate wire should be used for this Earth ground, that is, not combined with one of the power leads.

6 Repeaters and trunked networks

6.1 Communication beyond line-of-sight through relays

At VHF and UHF, some type of relay system or network is required for reliable communications beyond line-of-sight.

6.2 Terrestrial repeater

A single repeater station in a favourable location (on a hill or atop a building) may be used to retransmit signals between points not having line-of-sight.

6.3 Trunked land mobile radio systems with a central controller

Trunking is the automatic sharing of a common pool of possibly 10 or more frequencies in a multiple repeater system. Trunking may be performed at a single site or multiple sites for wide-area coverage.

Trunked systems are based on the premise that each user transmits only a small percentage of time, thus it is possible to provide more overall capacity with a band than if each station or group of users had its own frequency. Linked repeaters provide better geographical coverage than a single repeater. A trunked network includes some redundancy, which can be beneficial in disaster situations. If prearranged, trunked systems may include an emergency feature for speech or data calls to specified mobile units.

A trunked system has at least one control channel that continuously transmits the computer-generated digital data needed to control vehicular and hand-held radios within range. Channels are assigned to a group only when there is traffic, making the channels free for other users. This is accomplished in a way that users hear only the traffic intended for their group and in a way that is completely transparent to the users. There are two types of trunking control systems, known as dedicated control channel and distributed control channel. In the dedicated control system, the control channel operates on one frequency. The distributed type uses any idle channel for control transmissions.

Mobile units are assigned identifiers and a home repeater. When a mobile unit is not transmitting, it always monitors the home repeater for data messages. When a mobile transmits, it identifies through a digital handshake protocol that takes only a fraction of a second.

Characteristics of digital land mobile systems are described in Report ITU-R M.2014. These systems include a trunked and non-trunked capability to permit direct mobile-to-mobile and group speech call facilities with user options to permit selective and secure calling.

6.4 Trunked land mobile radio systems without a central controller

There are also trunking systems using multi-channel access techniques and appropriate protocols that do not require a central controller for the detection of an idle radio channel, known as “Personal Radio System” and “Digital Short Range Radio”. Both systems work in the 900 MHz frequency band. They provide up to 80 channels and use a transmit power of up to 5 W. More detailed data of these systems are given in Recommendation ITU-R M.1032.

Figure 16 – In the top drawing, stations A and B are unable to interoperate because propagation is blocked by hills. In the bottom drawing, a repeater station is able to relay signals between stations A and B

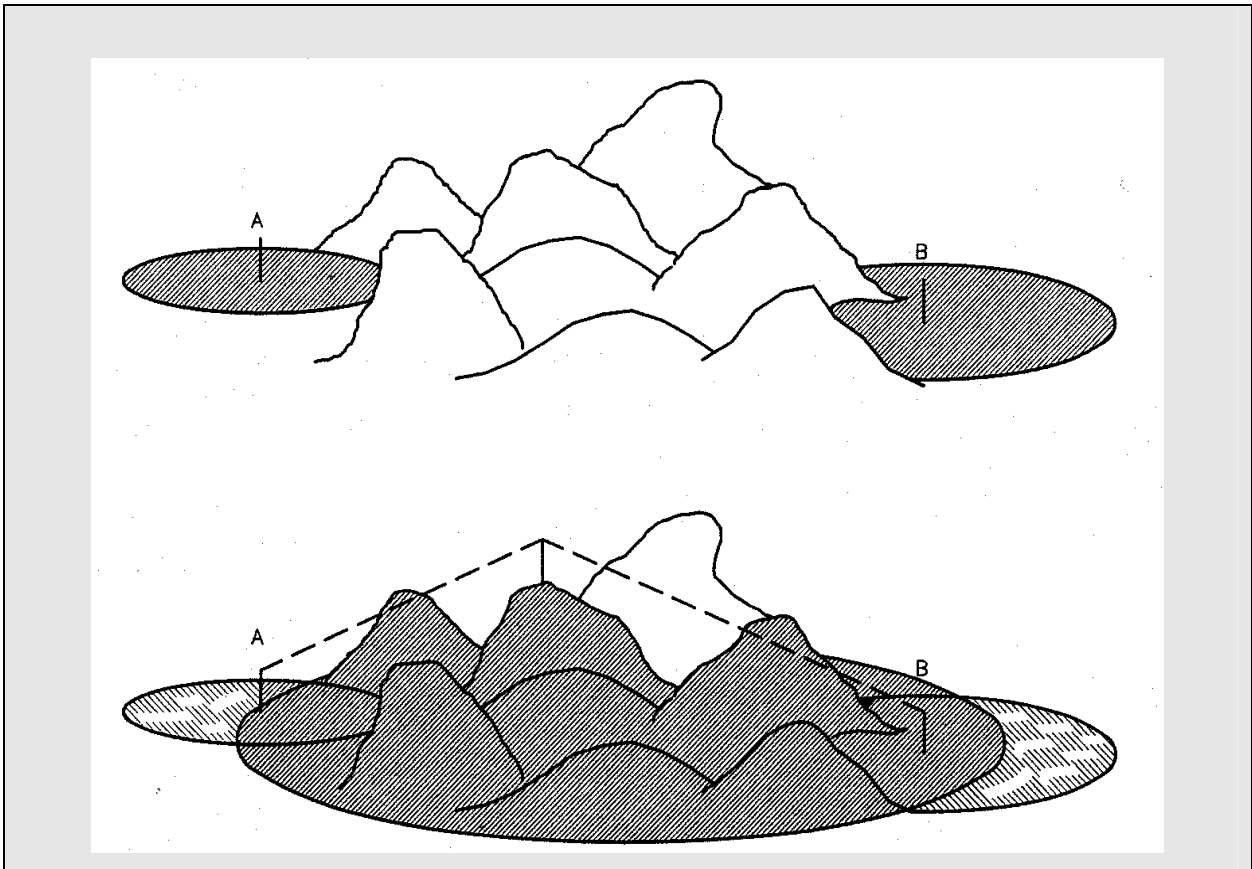

All radios in these systems are normally in the standby state on a control channel, ready to receive a selective calling signal. A calling station looks for and finds an idle traffic channel and stores its number in its memory. Then the calling station transmits on a control channel, a selective calling signal including at least its own identity, the identity of the called station and the number of the identified idle channel. The standby stations detecting their identity code in the received signal, move to the indicated traffic channel and enter into communication. At the end of the communication all units return again to the standby mode.

List of commonly used abbreviations

| | |
|---------|--|
| A | Ampere |
| ac | Alternating current |
| A/D | Analogue-to-digital |
| Ah | Ampere-hour |
| AM | Amplitude modulation |
| AMTOR | AMateur Teleprinting Over Radio |
| ARES | Amateur Radio Emergency Service |
| ARQ | Automatic Repeat reQuest (error-control technique) |
| AX.25 | Amateur Packet Radio Link Layer Protocol |
| CANTO | Caribbean Association of National Telecommunications Operators |
| CDERA | Caribbean Disaster Emergency Response Agency |
| CENTREX | Central Exchange |
| CEO | Chief Executive Officer |
| COW | Cell On Wheels |
| CP | Command Post |
| CQ | General call (to all radio stations) |
| CW | Carrier wave (Morse radiotelegraphy) |
| DAMA | Demand assigned multiple access |
| DECT | Digital Enhanced Cordless Telephone |
| DDI | Direct dial in |
| DHA | Department of Humanitarian Affairs (now OCHA) |
| DMT | Disaster Management Team (UN) |
| DSC | Digital Selective Calling |
| DSL | Digital Subscriber Line |
| DSP | Digital Signal Processing |
| EDGE | Enhanced Data Rates for GSM Evolution |
| ELT | Emergency Location Transmitter |
| EOC | Emergency Operations Centre |
| Fax | Facsimile |
| FD | Field Day (amateur) |
| FEC | Forward Error Control |
| FM | Frequency modulation |
| FSTV | Fast scan television |
| FTP | File Transfer Protocol |

Handbook on Emergency Telecommunications

| | |
|---------|--|
| GAN | Global Area Network |
| GETS | Government Emergency Telecommunications |
| GLONASS | GLObal Navigation Satellite System |
| GMDSS | Global Maritime Distress and Safety System |
| GMPCS | Global Mobile Personal Communications by Satellite |
| GPS | Global Positioning System |
| GSM | Global System for Mobile Communications |
| GSO | Geostationary orbit (satellite) |
| GTC | Grameen Telecom |
| HAZMAT | Hazardous materials |
| HF | High frequencies (3-30 MHz) |
| HTML | Hypertext Markup Language |
| IAPSO | The Inter-Agency Procurement Services Office (UNDP) |
| IARU | International Amateur Radio Union (NGO) |
| IASC | Inter Agency Standing Committee (UN advisory body) |
| ICAO | International Civil Aeronautical Organisation |
| ICET | Intergovernmental Conference on Emergency Telecommunications |
| ICRC | International Committee of the Red Cross |
| IDNDR | International Decade for Natural Disaster Reduction |
| IEPREP | Internet Emergency Preparedness |
| IF | Intermediate frequency |
| IFRC | International Federation of Red Cross and Red Crescent Societies |
| IMO | International Maritime Organization |
| IP | Internet Protocol |
| ISDN | Integrated Services Digital Network |
| ITA | International Telegraph Alphabet |
| ITU | International Telecommunication Union |
| ITU-D | Telecommunication Development Sector (ITU) |
| ITU-R | Radiocommunication Sector (ITU) |
| ITU-T | Telecommunication Standardization Sector (ITU) |
| kW | Kilowatt |
| LAN | Local area network |
| LEO | Low Earth orbit (satellite) |
| LES | Land earth station |
| MESA | Mobility for Emergency and Safety Applications |
| MMSI | Maritime Mobile Service Indicator |

| | |
|--------|--|
| NCS | Net Control Station |
| NGN | Next Generation Networks |
| NGO | Non-governmental organisation |
| NiCd | Nickel cadmium (cell) |
| NiMH | Nickel metal hydride (cell) |
| NOTAM | Notice to Airmen |
| NVIS | Near-vertical-incidence-sky wave (propagation) |
| OCHA | Office for the Coordination of Humanitarian Affairs (UN) |
| OSOCC | On-side operations coordination centre |
| PACSAT | Packet (radio) satellite |
| PACTOR | PAcket Transmission Over Radio |
| PBBS | Packet bulletin board system |
| PBX | Private Branch Exchange |
| PCS | Personal Communications Systems |
| PLB | Personal locator beacon |
| PLMN | Public Land Mobile Network |
| POP | Post Office Protocol |
| POTS | Plain Old Telephone System |
| PSAP | Public Access Point |
| PSTN | Public Switched Telephone Network |
| RBGAN | Regional Broadband Global Area Network |
| RBS | Radio base station |
| RF | Radio frequency |
| ROBO | Remote Office – Branch Office |
| RTTY | Radioteletype (narrow-band direct-printing radiotelegraph) |
| SCIP | Secure Communication Interoperability Protocol |
| SDR | Swiss Disaster Relief Unit, Software Defined Radio |
| SELCAL | Selective Calling |
| SET | Simulated Emergency Test |
| SITOR | Simplex Teletype Over Radio (narrow-band direct-printing radiotelegraphy system used in the maritime mobile service) |
| SOHO | Small Office – Home Office |
| SOLAS | Safety of Life at Sea |
| SRSA | Swedish Rescue Services Agency |
| SSB | Single sideband |
| SSTV | Slow scan television |

Handbook on Emergency Telecommunications

| | |
|--------|---|
| SWR | Standing wave ratio |
| TCP/IP | Transmission Control Protocol/Internet Protocol |
| TCO | Telecommunications Coordination Officer |
| TNC | Terminal Node Controller (packet radio) |
| UNHCR | United Nations High Commissioner for Refugees |
| UNDAC | United Nations Disaster Assessment and Coordination |
| UNDP | United Nations Development Programme |
| UNICEF | United Nations Children's Fund |
| UNOG | United Nations Organisation, Geneva |
| UNB | Ultra Wide Band |
| UHF | Ultra high frequencies (30-3 000 MHz) |
| USAT | Ultra small aperture terminal |
| USB | Upper Side Band |
| USD | United States Dollar |
| V | Volt |
| VHF | Very high frequencies (30-300 MHz) |
| VPN | Virtual Private Network |
| VITA | Volunteers in Technical Assistance |
| VSAT | Very Small Aperture Terminal |
| W | Watt |
| WAN | Wide area network |
| WAP | Wireless Access Protocol |
| WFP | World Food Programme |
| WHO | World Health Organization (UN) |
| WI-FI | Wireless Fidelity |
| WLL | Wireless local loop (generally replaced by fixed wireless access (FWA)) |
| WTDC | World Telecommunication Development Conference |
| WGET | Working Group on Emergency Telecommunications |
| WRC | World Radiocommunication Conference |
| WWRF | World Wide Research Forum |
| WWW | World Wide Web |

Morse code signals¹

1.1 The following are the written characters that may be used and the corresponding Morse code signals:

1.1.1 Letters

| | | | | | |
|------------|------|---|------|---|------|
| a | .- | i | .. | r | .-. |
| b | -... | j | .--- | s | ... |
| c | -.-. | k | -.- | t | - |
| d | -.. | l | .-.. | u | ..- |
| e | . | m | -- | v | ...- |
| accented e | ..-. | n | -. | w | .-. |
| f | ..-. | o | --- | x | -.- |
| g | --. | p | ---. | y | -.-- |
| h | | q | --.- | z | --.. |

1.1.2 Figures

| | | | |
|---|-------|---|--------|
| 1 | .---- | 6 | -..... |
| 2 | ..--- | 7 | --.... |
| 3 | ...-- | 8 | ---.. |
| 4 | ...- | 9 | ----- |
| 5 | | 0 | ----- |

1.1.3 Punctuation marks and miscellaneous signs

| | | |
|---|-----|--------|
| Full stop (period)..... | [.] | .-.-. |
| Comma..... | [,] | --..- |
| Colon or division sign..... | [:] | ---... |
| Question mark (note of interrogation or request for repetition of a transmission not understood)..... | [?] | ..--.. |
| Apostrophe..... | ['] | .-.... |
| Hyphen or dash or subtraction sign..... | [-] | -....- |
| Fraction bar or division sign..... | [/] | ..-. |
| Left-hand bracket (parenthesis)..... | [(| --.. |
| Right-hand bracket (parenthesis)..... |) | ..--. |

¹ From Recommendation ITU-T F.1 Division B.

Handbook on Emergency Telecommunications

| | | |
|--|------|---------|
| Inverted commas (quotation marks)(before and after the words)..... | [“”] | .-.-. |
| Double hyphen..... | [=] | -...- |
| Understood..... | | ...-. |
| Error (eight dots)..... | | |
| Email (at) Sign | [@] | ---.--. |
| Cross or addition sign..... | [+] | .-.-. |
| Invitation to transmit..... | | -.- |
| Wait | | .-... |
| End of work..... | | ...-.- |
| Starting signal (to precede every transmission)..... | | -.-- |
| Multiplication sign..... | [x] | -..- |

Phonetic alphabet code²

| Letter to be transmitted | Code word to be used | Spoken as |
|--------------------------|----------------------|--|
| A | Alfa | <u>AL</u> FAH |
| B | Bravo | <u>BRAH</u> VOH |
| C | Charlie | <u>CHAR</u> LEE or <u>SHAR</u> LEE |
| D | Delta | <u>DELL</u> TAH |
| E | Echo | <u>ECK</u> OH |
| F | Foxtrot | <u>FOKS</u> TROT |
| G | Golf | GOLF |
| H | Hotel | HOH <u>TELL</u> |
| I | India | <u>IN</u> DEE AH |
| J | Juliett | <u>JEW</u> LEE <u>ETT</u> |
| K | Kilo | <u>KEY</u> LOH |
| L | Lima | <u>LEE</u> MAH |
| M | Mike | MIKE |
| N | November | NO <u>VEM</u> BER |
| O | Oscar | <u>OSS</u> CAH |
| P | Papa | PAH <u>PAH</u> |
| Q | Quebec | KEH <u>BECK</u> |
| R | Romeo | <u>ROW</u> ME OH |
| S | Sierra | SEE <u>AIR</u> RAH |
| T | Tango | <u>TANG</u> GO |
| U | Uniform | <u>YOU</u> NEE FORM or <u>OO</u> NEE FORM |
| V | Victor | <u>VIK</u> TAH |
| W | Whiskey | <u>WISS</u> KEY |
| X | X-ray | <u>ECKS</u> RAY |
| Y | Yankee | <u>YANG</u> KEY |
| Z | Zulu | <u>ZOO</u> LOO |

² From Radio Regulations Appendix S14.

Figure code

| Figure or mark to be transmitted | Spoken as ³ (ICAO) | Code word (Appendix S14) | Spoken as (Appendix S14) |
|----------------------------------|-------------------------------|--------------------------|--------------------------|
| 0 | ZE-RO | Nadazero | NAH-DAH-ZAY-ROH |
| 1 | WUN | Unaone | OO-NAH-WUN |
| 2 | TOO | Bissotwo | BEES-SOH-TOO |
| 3 | TREE | Terrathree | TAY-RAH-TREE |
| 4 | FOW er | Kartefour | KAR-TAY-FOWER |
| 5 | FIFE | Pantafive | PAN-TAH-FIVE |
| 6 | SIX | Soxisix | SOK-SEE-SIX |
| 7 | SEV en | Setteseven | SAY-TAY-SEVEN |
| 8 | AIT | Oktoeight | OK-TOH-AIT |
| 9 | NIN er | Novenine | NO-VAY-NINER |
| Decimal point | DAY SEE MAL | Decimal | DAY-SEE-MAL |
| Hundred | HUN dred | | |
| Thousand | TOU SAND | | |

³ From ICAO Radiotelephony Procedures.

Q Code⁴

Certain Q code abbreviations may be given an affirmative or negative sense by sending, immediately following the abbreviation, the letter C or the letters NO (in radiotelephony spoken as: CHARLIE or NO).

The meanings assigned to Q code abbreviations may be amplified or completed by the addition of other appropriate groups, call signs, place names, figures, numbers, etc. It is optional to fill in the blanks shown in parentheses. Any data which are filled in where blanks appear shall be sent in the same order as shown in the text of the following tables.

Q code abbreviations are given the form of a question when followed by a question mark in radiotelegraphy and RQ (ROMEO QUEBEC) in radiotelephony. When an abbreviation is used as a question and is followed by additional or complementary information, the question mark (or RQ) should follow this information.

All times shall be given in Coordinated Universal Time (UTC) unless otherwise indicated in the question or reply.

| Abbreviation | Question | Answer or Advice |
|--------------|---|---|
| QRA | What is the name of your vessel (<i>or</i> station)? | The name of my vessel (<i>or</i> station) is ... |
| QRB | How far approximately are you from my station? | The approximate distance between our stations is ... nautical miles (<i>or</i> kilometres). |
| QRG | Will you tell me my exact frequency (<i>or</i> that of ...)? | Your exact frequency (<i>or</i> that of ...) is ... kHz (<i>or</i> MHz). |
| QRH | Does my frequency vary? | Your frequency varies. |
| QRI | How is the tone of my transmission? | The tone of your transmission is ... 1. good 2. variable 3. bad. |
| QRK | What is the intelligibility of my signals (<i>or</i> those of ... (<i>name and/or call sign</i>))? | The intelligibility of your signals (<i>or</i> those of ... (<i>name and/or call sign</i>)) is ... 1. bad 2. poor 3. fair 4. good 5. excellent. |

⁴ From Recommendation ITU-R M.1172, *Miscellaneous abbreviations and signals to be used for radiocommunications in the maritime mobile service*, Radio Regulations (1998).

Handbook on Emergency Telecommunications

| Abbreviation | Question | Answer or Advice |
|--------------|---|--|
| QRL | Are you busy? | I am busy (<i>or</i> I am busy with ... (<i>name and/or call sign</i>)). Please do not interfere. |
| QRM | Is my transmission being interfered with? | Your transmission is being interfered with ... 1. nil 2. slightly 3. moderately 4. severely 5. extremely. |
| QRZ | Who is calling me? | You are being called by ... (on ... kHz(<i>or</i> MHz)). |
| QSA | What is the strength of my signals (<i>or</i> those of ... (<i>name and/or call sign</i>))? | The strength of your signals (<i>or</i> those of ... (<i>name and/or call sign</i>)) is ... 1. scarcely perceptible 2. weak 3. fairly good 4. good 5. very good. |
| QSB | Are my signals fading? | Your signals are fading. |
| QSO | Can you communicate with ... (<i>name and/or call sign</i>) direct (<i>or</i> by relay)? | I can communicate with ... (<i>name and/or call sign</i>) direct (<i>or</i> by relay through ...). |
| QSP | Will you relay to ... (<i>name and/or call sign</i>) free of charge? | I will relay to ... (<i>name of and/or call sign</i>) free of charge. |
| QSV | Shall I send a series of Vs (<i>or</i> signs) for adjustment on this frequency (<i>or</i> on ... kHz (<i>or</i> MHz))? | Send a series of Vs (<i>or</i> signs) for adjustment on this frequency (<i>or</i> on ... kHz (<i>or</i> MHz)). |
| QSW | Will you send on this frequency (<i>or</i> on ... kHz (<i>or</i> MHz)) (with emissions of class ...)? | I am going to send on this frequency (<i>or</i> on ... kHz (<i>or</i> MHz)) (with emissions of class ...). |
| QSX | Will you listen to ... (<i>name and/or call sign(s)</i>) on ... kHz (<i>or</i> MHz), or in the bands .../channels ...? | I am listening to ... (<i>name and/or call sign(s)</i>) on ... kHz (<i>or</i> MHz), or in the bands .../channels ... |
| QSY | Shall I change to transmission on another frequency? | Change to transmission on another frequency (<i>or</i> on ... kHz (<i>or</i> MHz)). |
| QSZ | Shall I send each word or group more than once? | Send each word or group twice (<i>or</i> ... times). |

| Abbreviation | Question | Answer or Advice |
|--------------|--|---|
| QTA | Shall I cancel telegram (<i>or</i> message) number ...? | Cancel telegram (<i>or</i> message) number ... |
| QTC | How many telegrams have you to send? | I have ... telegrams for you (<i>or</i> for ... (<i>name and/or call signs</i>)). |
| QTH | What is your position in latitude and longitude (<i>or according to any other indication</i>)? | My position is ... latitude, ... longitude (<i>or according to any other indication</i>). |
| QTR | What is the correct time? | The correct time is ... hours. |

Miscellaneous Abbreviations and Signals⁵

| Abbreviation or signal | Definition |
|------------------------|---|
| AA | All after ... (used after a question mark in radiotelegraphy or after RQ in radiotelephony (in case of language difficulties) or after RPT, to request a repetition). |
| AB | All before ... (used after a question mark in radiotelegraphy or after RQ in radiotelephony (in case of language difficulties) or after RPT, to request a repetition). |
| ADS | Address (used after a question mark in radiotelegraphy or after RQ in radiotelephony (in case of language difficulties) or after RPT, to request a repetition). |
| AR, — | End of transmission. |
| AS, — | Waiting period. |
| BK | Signal used to interrupt a transmission in progress. |
| BN | All between ... and ... (used after a question mark in radiotelegraphy or after RQ in radiotelephony (in case of language difficulties) or after RPT, to request a repetition). |
| BQ | A reply to an RQ. |
| BT, — | Signal to mark the separation between different parts of the same transmission. |
| C | Yes or “The significance of the previous group should be read in the affirmative”. |
| CFM | Confirm (or I confirm). |
| CL | I am closing my station. |
| COL | Collate (or I collate). |
| CORRECTION | Cancel my last word or group. The correct word or group follows (used in radiotelephony, spoken as KOR-REK-SHUN). |
| CQ | General call to all stations. |
| CS | Call sign (used to request a call sign). |
| DE | “From ...” (used to precede the name or other identification of the calling station). |
| K | Invitation to transmit. |
| KA, — | Starting signal. |
| MIN | Minute (or Minutes). |
| NIL | I have nothing to send to you. |
| NO | No (negative). |
| NW | Now. |
| OK | We agree (or It is correct). |

⁵ From Recommendation ITU-R M.1172 Miscellaneous abbreviations and signals to be used for radiocommunications in the maritime mobile service, Radio Regulations (1998).

| Abbreviation or signal | Definition |
|------------------------|---|
| PBL | Preamble (<i>used after a question mark in radiotelegraphy or after RQ in radiotelephony (in case of language difficulties) or after RPT, to request a repetition</i>). |
| PSE | Please. |
| R | Received. |
| REF | Reference to ... (<i>or Refer to ...</i>). |
| RPT | Repeat (<i>or I repeat</i>) (<i>or Repeat ...</i>). |
| RQ | Indication of a request. |
| SIG | Signature (<i>used after a question mark in radiotelegraphy or after RQ in radiotelephony (in case of language difficulties) or after RPT, to request a repetition</i>). |
| SVC | Prefix indicating a service telegram. |
| SYS | Refer to your service telegram. |
| TFC | Traffic. |
| TU | Thank you. |
| TXT | Text (<i>used after a question mark in radiotelegraphy or after RQ in radiotelephony (in case of language difficulties) or after RPT, to request a repetition</i>). |
| VA, — | End of work. |
| WA | Word after ... (<i>used after a question mark in radiotelegraphy or after RQ in radiotelephony (in case of language difficulties) or after RPT, to request a repetition</i>). |
| WD | Word(s) <i>or</i> Group(s). |
| WX | Weather report (<i>or Weather report follows</i>). |

Note: When used in radiotelegraphy, a bar over the letters composing a signal denotes that the letters are to be sent as one signal.

Procedure words⁶

Signal strength and readability

| Signal strength | |
|-----------------|--|
| Spoken | Meaning |
| LOUD | Your signal is strong. |
| GOOD | Your signal is good. |
| WEAK | I can hear you but with difficulty. |
| VERY WEAK | I can hear you but with great difficulty |
| NOTHING HEARD | I cannot hear you at all. |

| Readability | |
|-------------------|--|
| Spoken | Meaning |
| CLEAR | Excellent quality. |
| READABLE | Good quality, no difficulty in reading you. |
| DISTORTED | I have problems reading you. |
| WITH INTERFERENCE | I have problems reading you due to interference. |
| NOT READABLE | I can hear that you are transmitting but cannot read you at all. |

| Procedure word | Meaning |
|----------------|---|
| ACKNOWLEDGE | Confirm that you have received my message and will comply (WILCO) |
| AFFIRMATIVE | Yes/Correct |
| ALL AFTER | Everything that you transmitted after ... |
| ALL BEFORE | Everything that you transmitted before ... |
| BREAK | Indicates separation of text from rest of message. |
| BREAK BREAK | I wish to interrupt an ongoing exchange of transmissions in order to pass an urgent message. |
| CALL SIGN | The group that follows is a call sign. |
| CANCEL | Annul the previously transmitted message. |
| CORRECT | You are correct or what you have transmitted is correct. |
| CORRECTION | An error has been made in this transmission (or message indicated). The correct version is ... |
| DISREGARD | Consider that transmission as not sent. |

⁶ Adapted from UNHCR Procedure for Radio Communication and supplemental sources.

| Procedure word | Meaning |
|---------------------|--|
| DO NOT ANSWER – OUT | Station(s) called are not to answer this call, acknowledge this message, or to transmit in connection with this transmission |
| FIGURES | Numerals or numbers will follow. |
| HOW DO YOU READ? | What is the readability of my signal? |
| I SAY AGAIN | I repeat for clarity or emphasis. |
| MESSAGE FOLLOWS | I have a formal message which should be recorded (e.g.) written down |
| MONITOR | Listen out on ... (frequency). |
| NEGATIVE | No/Incorrect |
| OVER | This is the end of this transmission and a response is necessary. |
| OUT | This is the end of my transmission. No answer is required or expected. (OVER and OUT are never used together.) |
| READ BACK | Repeat this entire transmission back to me exactly as received. |
| RELAY (TO) | Transmit the following message to all addressees or to the address immediately following ... |
| REPORT | Pass me the following information ... |
| ROGER | I have received your last transmission. (Not an answer to a question.) |
| SAY AGAIN | Repeat your last transmission or repeat the portion indicated by “ALL AFTER”. |
| SILENCE | Cease all transmission immediately. Maintain until lifted. |
| SILENCE LIFTED | Transmissions may resume after SILENCE has been previously ordered. |
| SPEAK SLOWER | Your transmissions are too fast. Reduce speed. |
| UNKNOWN STATION | The identity of the station heard is unknown. |
| VERIFY | Verify the entire message (or portion indicated) with the originator and send corrected version. To be used only when the addressee has serious questions about the validity of the message. |
| WAIT | Wait for a few seconds. |
| WAIT OUT | Wait for a longer period. I will re-establish contact when I return on the air. |
| WILCO | I have received your message and will comply. (ROGER is implied but not stated.) |
| WORD AFTER | The word of the message to which I refer is that which follows ... |
| WORD BEFORE | The word of the message to which I refer is that which precedes ... |
| WORDS TWICE | Communication is difficult. Transmit each word or phrase twice. |
| WRONG | The last transmission was incorrect. The correct version is ... |

RECOMMENDATION ITU-R P.1144-1

GUIDE TO THE APPLICATION OF THE PROPAGATION METHODS
OF RADIOCOMMUNICATION STUDY GROUP 3

(1995-1999)

The ITU Radiocommunication Assembly,

considering

a) that there is a need to assist users of the ITU-R Recommendations P Series (developed by Radiocommunication Study Group 3),

recommends

1 that the information contained in Table 1 be used for guidance on the application of the various propagation methods contained in the ITU-R Recommendations P Series (developed by Radiocommunication Study Group 3).

NOTE 1 – For each of the ITU-R Recommendations in Table 1, there are associated information columns to indicate:

Application: the service(s) or application for which the Recommendation is intended.

Type: the situation to which the Recommendation applies, such as point-to-point, point-to-area, line-of-sight, etc.

Output: the output parameter value produced by the method of the Recommendation, such as path loss.

Frequency: the applicable frequency range of the Recommendation.

Distance: the applicable distance range of the Recommendation.

% time: the applicable time percentage values or range of values of the Recommendation; % time is the percentage of time that the predicted signal is exceeded during an average year.

% location: the applicable per cent location range of the Recommendation; % location is the percentage of locations within, say, a square with 100 to 200 m sides that the predicted signal is exceeded.

Terminal height: the applicable terminal antenna height range of the Recommendation.

Input data: a list of parameters used by the method of the Recommendation; the list is ordered by the importance of the parameter and, in some instances, default values may be used.

The information, as shown in Table 1, is already provided in the Recommendations themselves; however, the table allows users to quickly scan the capabilities (and limitations) of the Recommendations without the requirement to search through the text.

Table 1 – ITU-R radiowave propagation prediction methods

| Method | Application | Type | Output | Frequency | Distance | % time | % location | Terminal height | Input data |
|-------------------|---|----------------|-------------------------|---------------------|---|---|----------------|--|--|
| Rec. ITU-R P.368 | All services | Point-to-point | Field strength | 10 kHz to 30 MHz | 1 to 10 000 km | Not applicable | Not applicable | Ground-based | Frequency Ground conductivity |
| Rec. ITU-R P.370 | Broadcasting | Point-to-area | Field strength | 30 MHz to 1 000 MHz | 10 to 1 000 km | 1, 5, 10, 50 | 1 to 99 | Tx: effective height from less than 0 m to greater than 1 200 m Rx: 1.5 to 40 m | Distance Tx antenna height Frequency Percentage time Rx antenna height Terrain clearance angle Terrain irregularity Percentage locations |
| Rec. ITU-R P.1147 | Broadcasting | Point-to-area | Sky-wave field strength | 0.15 to 1.7 MHz | 50 to 12 000 km | 10, 50 | Not applicable | Not applicable | Latitude and longitude of Tx Latitude and longitude of Rx Distance Sunspot number Tx power Frequency |
| Rec. ITU-R P.452 | Services employing stations on the surface of the Earth; interference | Point-to-point | Path loss | 700 MHz to 30 GHz | Not specified but up to and beyond the radio horizon | 0.001 to 50 Average year and worst month | Not applicable | No limits specified | Path profile data Frequency Percentage time Tx antenna height Rx antenna height Latitude and longitude of Tx Latitude and longitude of Rx Meteorological data |
| Rec. ITU-R P.528 | Aeronautical mobile | Point-to-area | Path loss | 125 MHz to 15 GHz | 0 to 1 800 km (for aeronautical applications 0 km horizontal distance does not mean 0 km path length) | 5, 50, 95 | Not applicable | H1: 15 m to 20 km H2: 1 to 20 km | Distance Tx height Frequency Rx height Percentage time |
| Rec. ITU-R P.1146 | Land mobile Broadcasting | Point-to-area | Field strength | 1 to 3 GHz | 1 to 500 km | 1 to 99 | 1 to 99 | Tx \geq 1 m Rx: 1 to 30 m | Distance Frequency Tx antenna height Rx antenna height Percentage time Percentage location Terrain information |

Table 1 – ITU-R radiowave propagation prediction methods (continued)

| Method | Application | Type | Output | Frequency | Distance | % time | % location | Terminal height | Input data |
|------------------|---------------------------------|-----------------------------------|--|---|---|---|----------------|--|---|
| Rec. ITU-R P.529 | Land mobile | Point-to-area | Field strength | 30 MHz to 3 GHz (limited application above 1.5 GHz) | VHF: 10 to 600 km UHF: 1 to 100 km | VHF: 1, 10, 50 UHF: 50 | Unspecified | Base: 20 m to 1 km Mobile: 1 to 10 m | Distance Base antenna height Frequency Mobile antenna height Percentage time Ground cover |
| Rec. ITU-R P.530 | Line-of-sight Fixed links | Point-to-point Line-of-sight | Path loss Diversity improve- ment (clear air conditions) XPD Outage Error performance | Approximately 150 MHz to 40 GHz | Up to 200 km if line-of-sight | All percentages of time in clear-air conditions; 1 to 0.001 in precipitation conditions ⁽¹⁾ | Not applicable | High enough to ensure specified path clearance | Distance Tx height Frequency Rx height Percentage time Path obstruction data Climate data |
| Rec. ITU-R P.533 | Broadcasting Fixed Mobile | Point-to-point | Basic MUF Sky-wave field strength Available receiver power Signal-to-noise ratio LUF Circuit reliability | 2 to 30 MHz | 0 to 40 000 km | All percentages | Not applicable | Not applicable | Latitude and longitude of Tx Latitude and longitude of Rx Sunspot number Month Time(s) of day Frequencies Tx power Tx antenna type Rx antenna type |
| Rec. ITU-R P.534 | Fixed Mobile Broadcasting | Point-to-point via sporadic E | Field strength | 30 to 100 MHz | 0 to 4 000 km | 0 to 50 | Not applicable | Not applicable | Distance Frequency |
| Rec. ITU-R P.616 | Maritime mobile | As for Recommendation ITU-R P.370 | | | | | | | |
| Rec. ITU-R P.617 | Trans-horizon fixed links | Point-to-point | Path loss | > 30 MHz | 100 to 1 000 km | 20, 50, 90, 99, and 99.9 | Not applicable | No limits specified | Frequency Tx antenna gain Rx antenna gain Path geometry |
| Rec. ITU-R P.618 | Fixed satellite | Point-to-point | Path loss. Diversity gain and (for precipitation condition) XPD | 1 to 55 GHz | Any practical orbit height | 0.001-5 for attenuation; 0.001-1 for XPD | Not applicable | No limit | Meteorological data Frequency Elevation angle Height of earth station Separation and angle between earth station sites (for diversity gain) Antenna diameter and efficiency (for scintillation) Polarization angle (for XPD) |

Table 1 – ITU-R radiowave propagation prediction methods (*end*)

| Method | Application | Type | Output | Frequency | Distance | % time | % location | Terminal height | Input data |
|------------------|--------------------------------------|---------------------------------|--|--------------------|----------------------------|--|----------------|---------------------|--|
| Rec. ITU-R P.620 | Earth station frequency coordination | Coordination distance | Distance of which the required propagation loss is achieved | 100 MHz to 105 GHz | up to 1 200 km | 0.001 to 50 | Not applicable | No limits specified | Minimum basic transmission loss Frequency Percentage of time Earth-station elevation angle |
| Rec. ITU-R P.680 | Maritime mobile satellite | Point-to-point | Sea-surface fading Fade duration Interference (adjacent satellite) | 0.8-8 GHz | Any practical orbit height | To 0.001% via Rice-Nakagami distribution Limit of 0.01% for interference ⁽¹⁾ | Not applicable | No limit | Frequency Elevation angle Maximum antenna boresight gain |
| Rec. ITU-R P.681 | Land mobile satellite | Point-to-point | Path fading Fade duration Non-fade duration | 0.8 to 20 GHz | Any practical orbit height | Not applicable Percentage of distance travelled 1 to 80% ⁽¹⁾ | Not applicable | No limit | Frequency Elevation angle Percentage of distance travelled Approximate level of optical shadowing |
| Rec. ITU-R P.682 | Aeronautical mobile satellite | Point-to-point | Sea-surface fading | 1 to 2 GHz | Any practical orbit height | To 0.001% via Rice-Nakagami distribution ⁽¹⁾ | Not applicable | No limit | Frequency Elevation angle Polarization Maximum antenna boresight gain Antenna height |
| Rec. ITU-R P.684 | Fixed | Point-to-point | Sky-wave field strength | 30 to 500 kHz | 0 to 40 000 km | 50 | Not applicable | Not applicable | Latitude and longitude of Tx Latitude and longitude of Rx Distance Tx power Frequency |
| Rec. ITU-R P.843 | Fixed Mobile Broadcasting | Point-to-point via meteor-burst | Received power Burst rate | 30 to 100 MHz | 100 to 1 000 km | 0 to 5 | Not applicable | Not applicable | Frequency Distance Tx power Antenna gains |

⁽¹⁾ Time percentage of outage; for service availability, subtract value from 100.

